

82722 Corn Saver

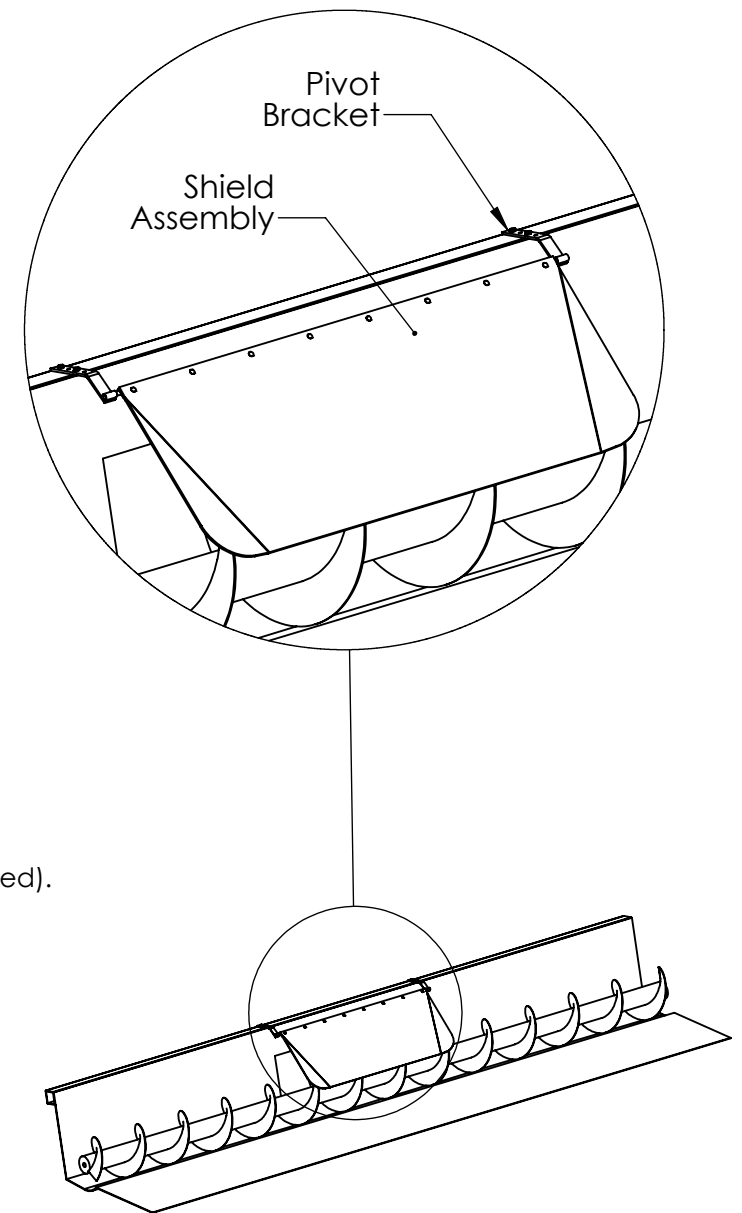
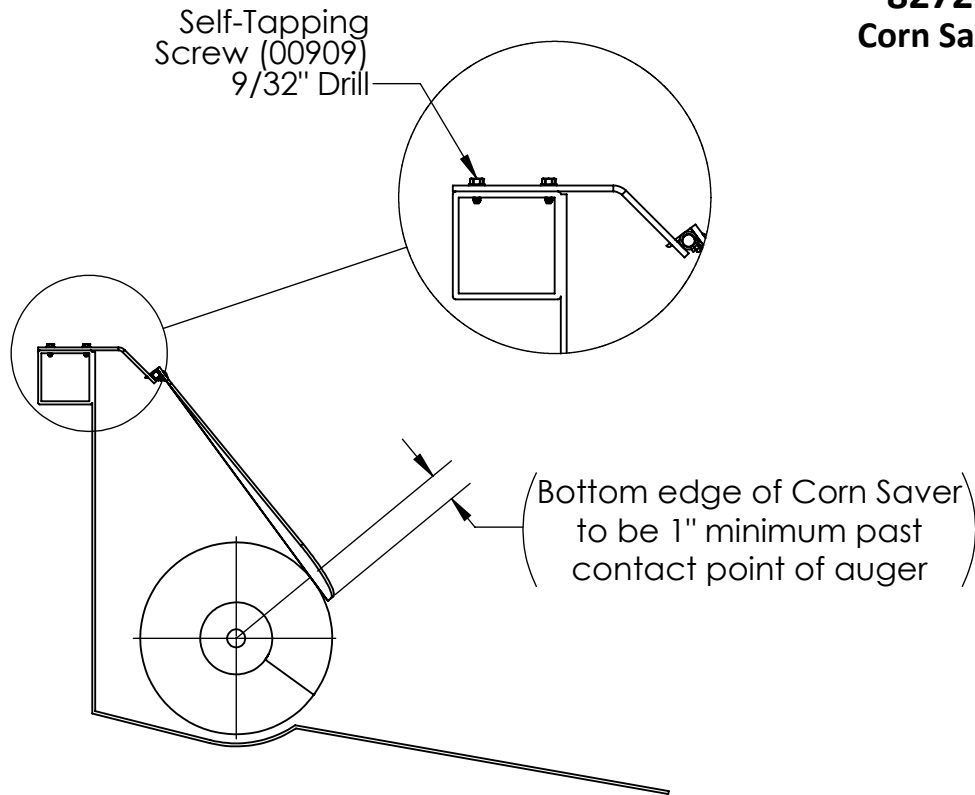

- Place pivot brackets (#41791) onto the shield assembly, center shield assembly with throat of corn head (this will determine where the pivot brackets will need to be mounted). Mark the holes thru the brackets for drilling locations where hardware will be used to mount. Make sure bottom edge of shield is a minimum 1" past contact point with auger.

- * Use self tapping screw if mounting to surface with **NO** backside access
- * Use nut/bolt combination if mounting to surface with backside access

- Drill holes in corn head:
 - Use included 9/32" drill for self-tapping screws (#00909)
 - Use 3/8" drill for nut(00714)/bolt(00073) combination
- Mount one pivot bracket onto header using supplied hardware. Place shield assembly inot bracket hole and then slide second pivot bracket onto shield assembly. Using supplied hardware attach second bracket to header.



120 Eastgate Drive SE
PO Box 7
Hutchinson, MN 55350

1-800-788-6483
1-320-587-2322
1-320-587-6112 (Fax)

WWW.MAYWES.COM

**82722
Corn Saver**

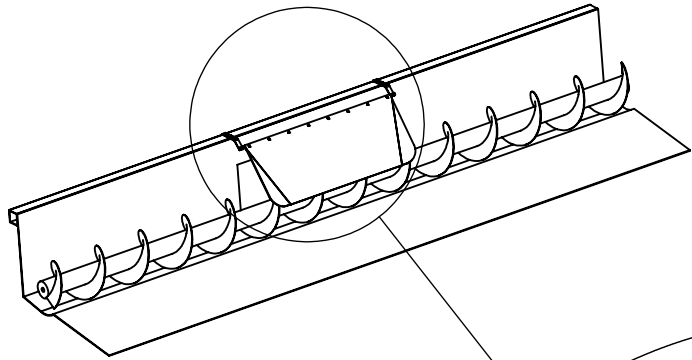

ITEM#	PART#	DESCRIPTION	QTY
1	41790	PIVOT FRAME WELDMENT	1
2	22312	DEFLECTOR SHIELD	1
3	41791	PIVOT WELDMENT	2
4	00167	BOLT, 1/4"-20 X 3/4" CARRAIGE	8
5	00917	NUT, 1/4"-20 FLANGE LOCK HEX	8
6	00909	BOLT, 5/16"-18 X 3/4 SELF THREAD HEX	4
7	00073	BOLT, 5/16"-18 X 1-1/4" HEX	4
8	00714	NUT, 5/16"-18 FLANGE HEX	4

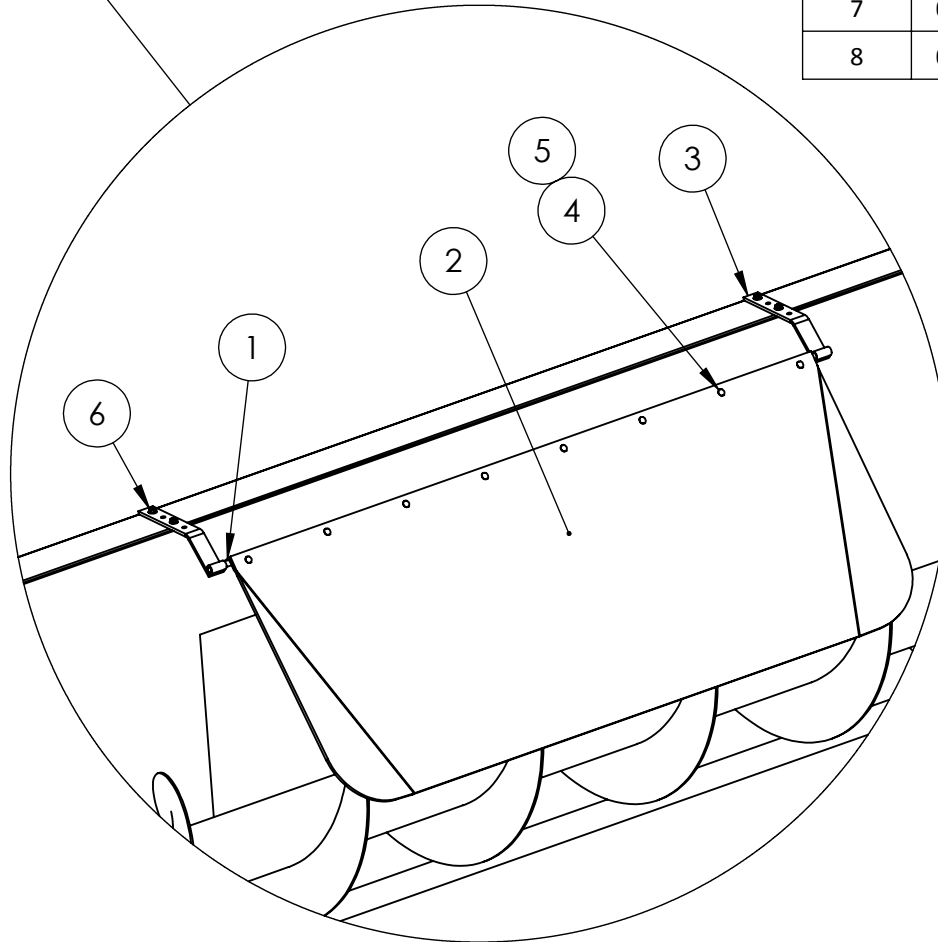

MAY WES
Original Poly People
A DIVISION OF PRIDE SOLUTIONS

120 Eastgate Drive SE
PO Box 7
Hutchinson, MN 55350

1-800-788-6483
1-320-587-2322
1-320-587-6112 (Fax)

WWW.MAYWES.COM