

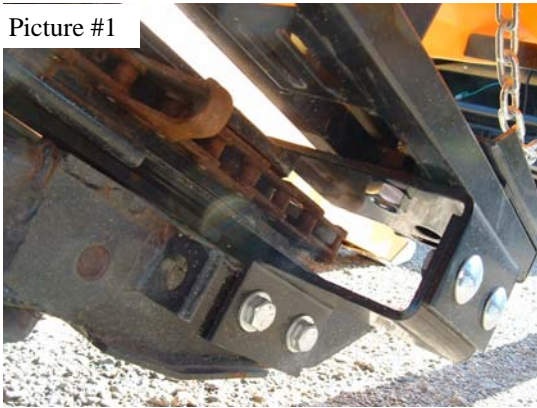

The Original Farmer Designed
59711 U.S. Hwy 12, Litchfield, MN 55355
1-888-485-8411

Assembly Instructions AGCO 3000 & Hugger-20's End Right (4416 or 4416-S) (H 4423 or H 4423-S)

Picture #1



Picture #2



Picture #3



Picture #4



1. **For heads with metal shields:** Remove all hinges, hinge brackets and hold-down brackets.
2. Bolt the Lower Hold Down Bracket in the holes that are normally used to hold the original hinge bracket **(Picture #1)** using 1/2" x 1 1/4" Hex Head Bolts and 1/2" Washers to bolt the head. Leave loose.
3. Bolt the Upper Hold Down Bracket to the Lower Hold Down Bracket **(Picture #1)** using 1/2" x 1" Carriage Bolts.
4. Position upper hold down bracket level with row unit and Resting on top of chain guide.
5. Install 5/8" x 2 3/4" hold down pin in rear nut with jam nut under the bottom side. **(Picture #2)**
6. Bolt the front hold down bracket to the main frame using 4 - 3/8" x 1" Carriage Bolts. (Put the lip of the bracket pointing up with the carriage bolts also pointing upward with the nuts on top.) Leave loose. **(Picture #2)**
7. Bolt the back mounting angle **(Item #7)** to the back of the head, inside of the mounting plate. Use 5/16" x 3/4" Carriage bolts. Leave loose. **(Picture #3)**
8. Bolt the Back Mounting plate **with the lip inward** using the two rear slotted holes. Use 3/8" x 1" Hex Bolts and washers and 3/8" x 1" carriage bolt. **(Picture #4)**
9. To determine the height for the front of the rear mounting plate, temporarily position the end unit on the head.
10. Once the rear mounting plate is in position mark, drill and bolt the plate to the head using 5/16" x 3/4" Hex Bolts.
11. Remove the end unit.



The Original Farmer Designed
59711 U.S. Hwy 12, Litchfield, MN 55355
1-888-485-8411

Assembly Instructions AGCO 3000 & Hugger-20's End Right (4416 or 4416-S) (H 4423 or H 4423-S)

Picture #5

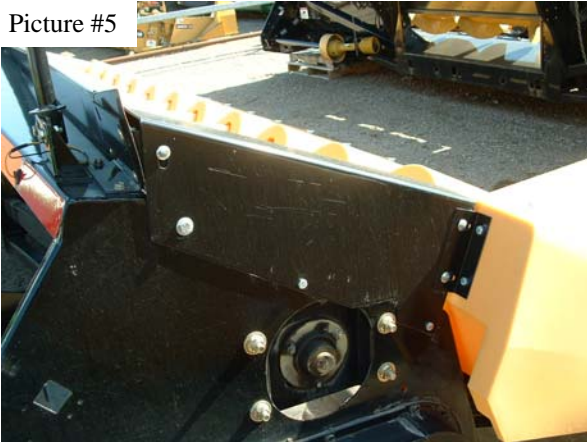

Picture #6

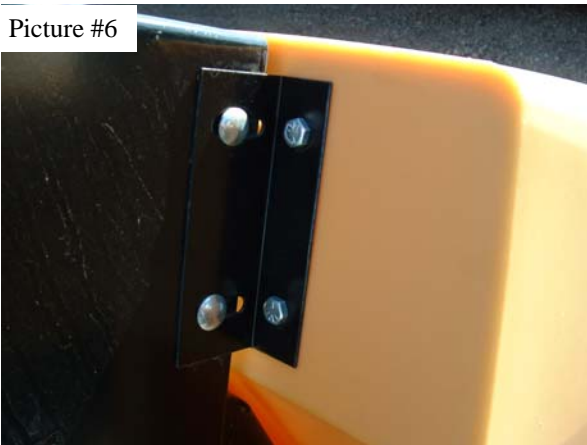

12. Install (2) 5/16" x 3/4" Carriage Bolts in the square holes at the front of the back mounting plate. (Threads to the outside.) Use the 5/16" bolt retainer to hold the bolts in place. **(Picture #5)**
13. Mount the back mounting angle **(Item #9)** on the mounting plate using the slotted holes and 5/16" nuts. **(Picture #5)**
14. Position the Gatherer, then drill and bolt the back mounting angle to the back of the Gatherer. (Use 5/16" x 3/4" Bolts). **(Picture # 6) .**
15. Position the gatherer shield and tighten all front hold down bolts.
16. Adjust the front hold down pin up or down so the lynch pin **(Item #13)** fits snug and tighten the jam nut. **(Picture #2)**
17. The PVC pipe around the adjustment chain must be removed. **(For shipping only.)**

ITEM NO.	PART NUMBER	DESCRIPTION	QTY.	ITEM NO.	PART NUMBER	DESCRIPTION	QTY.
35	SN-531	SERIAL NUMBER TAG	1	1	XX 14411	20's END RIGHT BACK SHORT	1
36	WP-96	Wear Point	1	2	XX 14400-S	20's RIGHT END SHORT	1
37	UN 21001	SS WEAR SRTIPS-LEFT EDGE	1	3	XX 14400	20's RIGHT END LONG	1
38	ES-GVL	GVL EAR SAVER	1	4	UN 04412	UNI RIGHT MAIN FRAME-20 LONG	1
39	516-W F	5/16 FENDER WASHER	4	5	UN 11403-S	END FRONT GATH BRKT-20-SHORT	1
40	DA 01419	END LOWER HOLD DOWN BRACKET	1	6	UN 11403	END FRONT GATH BRKT-20-LONG	1
41	516-NLN	5/16" NYLON LOCK NUT	2	7	DA 01404	BACK MNTG ANGLE-SHORT	1
				8	DA 04405	RIGHT REAR MOUNTING PLATE	1
				9	DA 01406	BACK MNTG ANGLE-LONG	1
				10	DA 01417	END FRONT HOLD DOWN BRKT	1
				11	DA 01418	END UPPER HOLD DOWN BRKT	1
				12	PCC-316	3/16 PROOF COIL CHAIN	21
				13	14-LP	1/4" LYNCH PIN	1
				14	58-234 HDP	5/8"x2 3/4" LG HOLD DOWN PIN	1
				15	58-JN	5/8" JAM NUT	1
				16	516-34 CB	5/16"x3/4" CARRAGE BOLT	4
				17	516-W USS	5/16" USS FLAT WASHER	4
				18	516-BR	5/16" BOLT RETAINER	2
				19	516-FSN	5/16" FLANGE SERRATED NUT	6
				20	516-34 HB	5/16"x3/4" HX HD BOLT	10
				21	38-1 CB	3/8"x1" CARR BOLT-SHORT NECK	5
				22	38-1 HB	3/8"x1" HX HD BOLT	2
				23	38-134 THB	3/8"x1 3/4" TRUSS HEAD BOLT	4
				24	38-3 UB	3/8"x3" U-BOLT	1
				25	38-FSN	3/8" FLANGE SERRATED NUT	11
				26	38-NLN	3/8" NYLON LOCK NUT	2
				27	38-W USS	3/8" USS FLAT WASHER	4
				28	12-1 CB	1/2" X 1" CARR BOLT	2
				29	12-114 HB	1/2"x1 1/4" HX HD BOLT	2
				30	12-FSN	1/2" FLANGE SERRATED NUT	2
				31	12-W SAE	1/2" SAE WASHER	4
				32	12-150 MHB	12X150 HX HD METRIC BOLT	2
				33	12-MLN	12 METRIC LOCK NUT	2
				34	14-34 TTS	1/4"x3/4" TR TAPPING SCREW	6

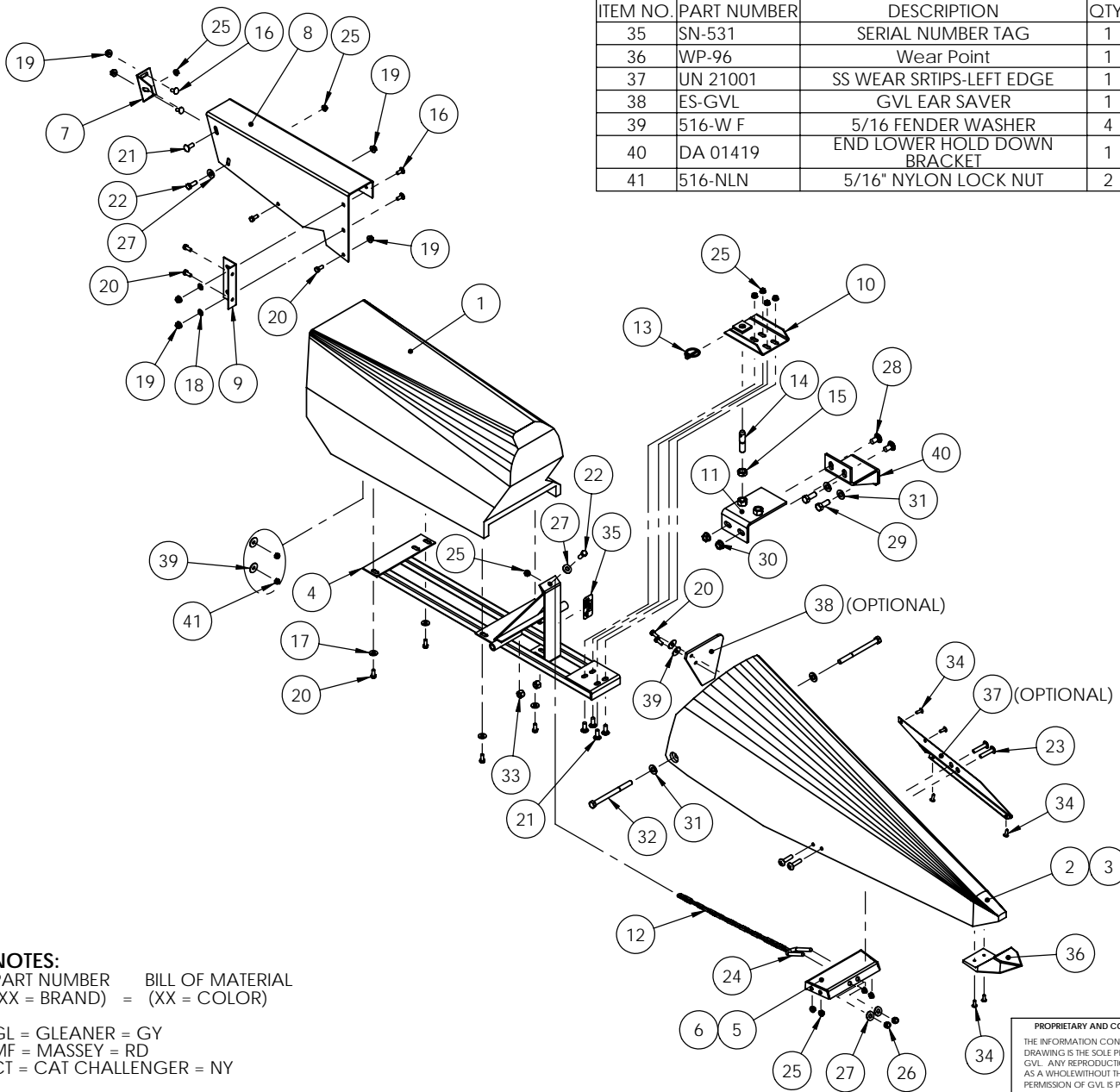

NOTES:
 PART NUMBER BILL OF MATERIAL
 (XX = BRAND) = (XX = COLOR)
 GL = GLEANER = GY
 MF = MASSEY = RD
 CT = CAT CHALLENGER = NY

PROPRIETARY AND CONFIDENTIAL
 THE INFORMATION CONTAINED IN THIS DRAWING IS THE SOLE PROPERTY OF GVL. ANY REPRODUCTION IN PART OR AS A WHOLE WITHOUT THE WRITTEN PERMISSION OF GVL IS PROHIBITED.

			GVL		
DRAWN	NAME	DATE	TITLE:		
ALS	ALS	5/15/08	AGCO 20's RIGHT END GVL I		
CHECKED					
ENG APPR.					
MFG APPR.					
Q.A.			COMMENTS:		
			SIZE	DWG. NO.	REV
			B	XX H 4423-S, XX H 4423 XX 4416-S, XX 4416	
			SCALE: 1:12	WEIGHT:	SHEET 1 OF 1