

## AGCO: GLEANER, MASSEY & CHALLENGER QD2 TOOLBAR MOUNT STALK STOMPER

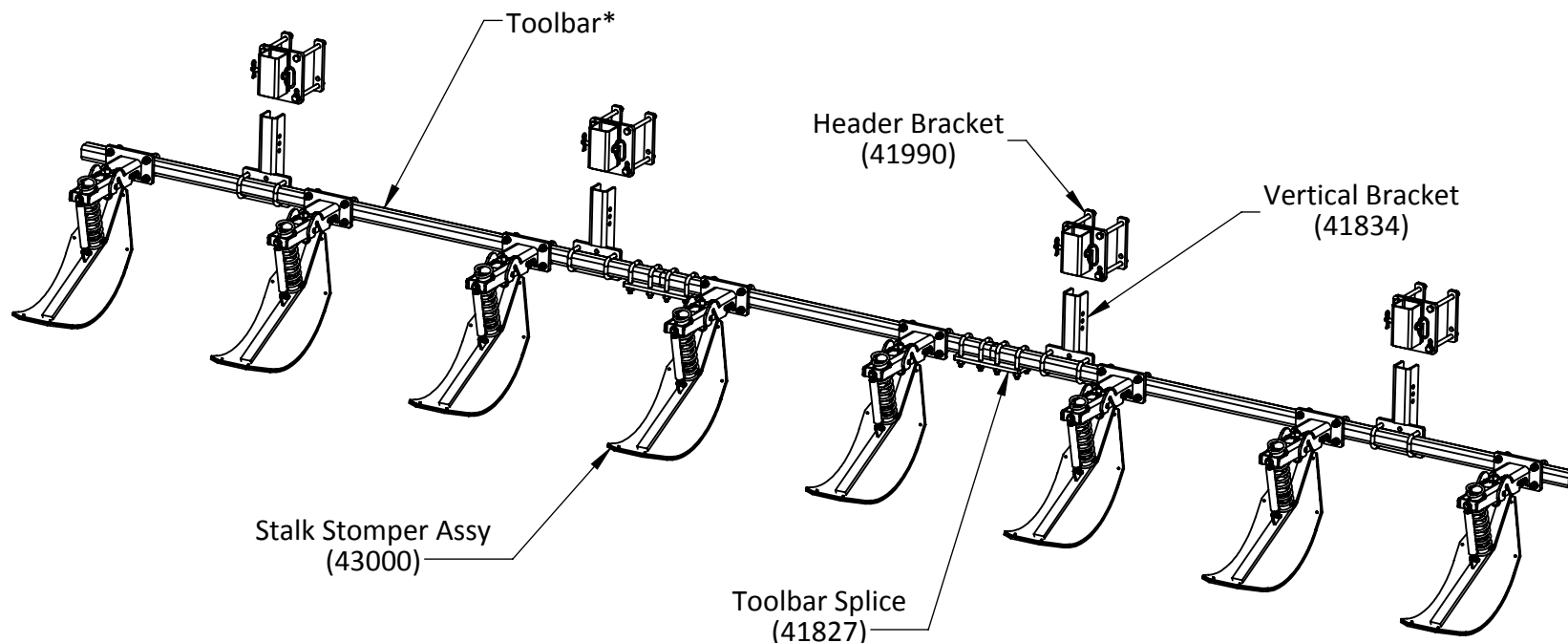

### Notes:

- Illustration shown is for reference purposes only. Quantities and components will vary. Please refer to individual component parts listings for specific information.
- Due to variation of implement configurations, row coverage under the feeder house may not be applicable.
- \* Toolbar is not included in all kits. If a kit without Toolbar was ordered, the customer is responsible for providing required Toolbar.



**MAY WES**  
*Original Poly People*  
A DIVISION OF PRIDE SOLUTIONS

120 Eastgate Drive SE  
PO Box 7  
Hutchinson, MN 55350

1-800-788-6483  
1-320-587-2322  
1-320-587-6112 (Fax)

[WWW.MAYWES.COM](http://WWW.MAYWES.COM)

## AGCO: GLEANER, MASSEY & CHALLENGER HEADER BRACKET INSTALLATION

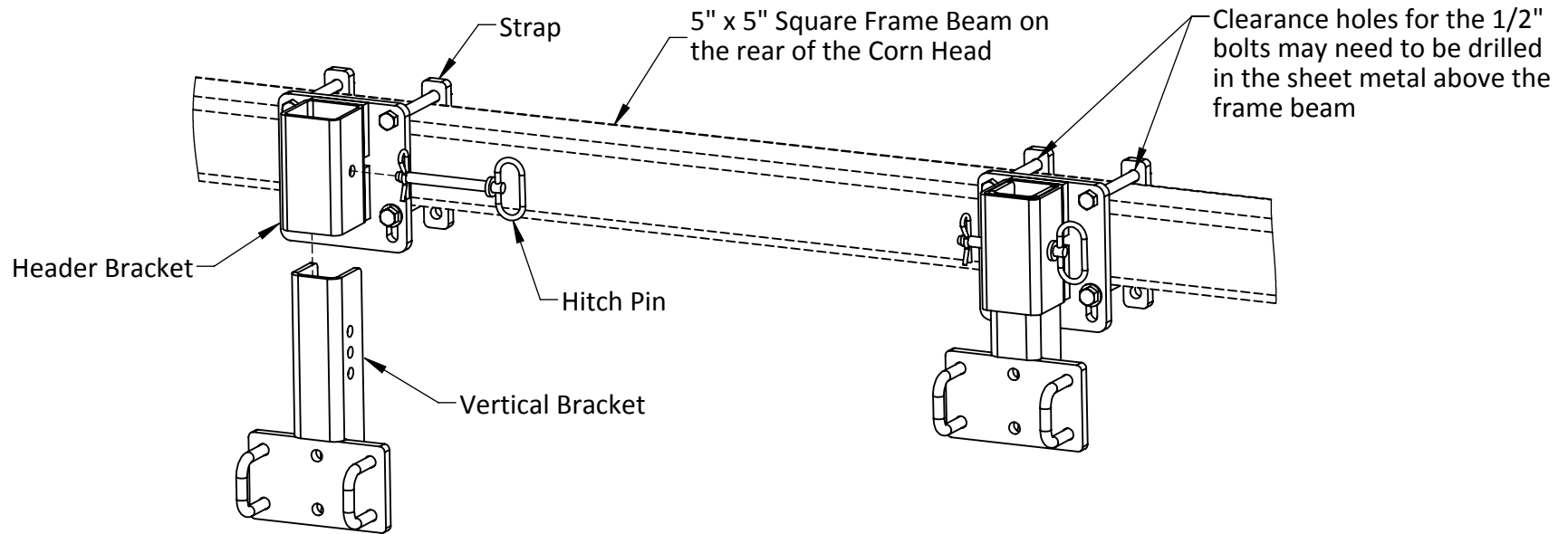

### Installation Procedure:

- Park combine on level ground and lock the brakes.
- Raise the head and lock in the upright position.
- Mount the Header Brackets to the square frame beam on the rear of the corn head using the straps, washers, bolts and nuts supplied. Mount two Header Brackets on each side of the head, positioning the brackets where needed while keeping as much distance between them as possible.

**Note:** Clearance holes may need to be drilled for the bolts at the top of the frame beam if sheet metal is present at determined mounting locations (see illustration).

- Install Vertical Brackets into Header Brackets and secure in place with Hitch Pins.
- Refer to the Toolbar Mount Stalk Stomper Instructions to continue installation.



**MAY WES**  
*Original Poly People*  
A DIVISION OF PRIDE SOLUTIONS

120 Eastgate Drive SE  
PO Box 7  
Hutchinson, MN 55350

1-800-788-6483  
1-320-587-2322  
1-320-587-6112 (Fax)

[WWW.MAYWES.COM](http://WWW.MAYWES.COM)

**AGCO: GLEANER, MASSEY & CHALLENGER**  
**TOOLBAR MOUNT STALK STOMPER**  
**ASSEMBLY INSTRUCTIONS / PARTS LISTING**

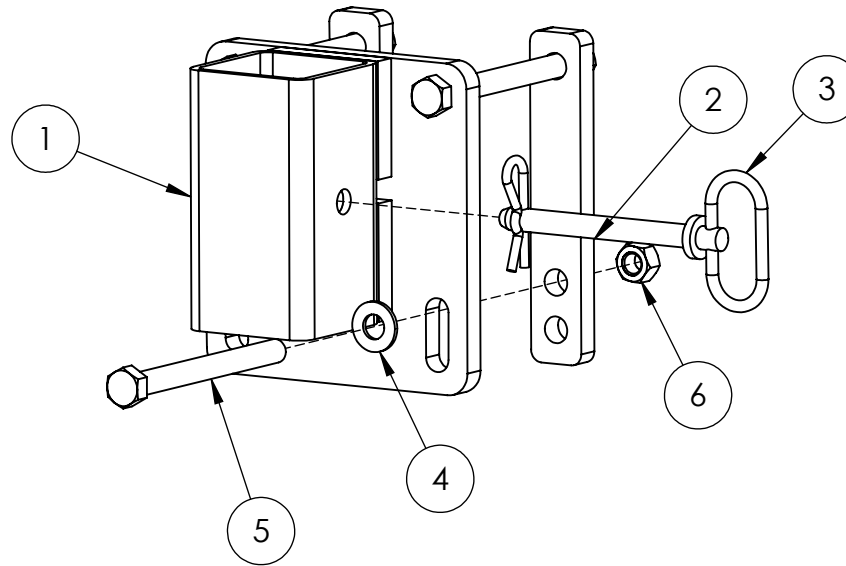

**41990**  
**HEADER BRACKET**

ITEM #	PART #	DESCRIPTION	QTY
1	41675	HEADER BRACKET	1
2	22198	STRAP	2
3	20433	HITCH PIN	1
4	00253	WASHER, 1/2" FLAT	2
5	00620	BOLT, 1/2"-13 X 7" HEX	4
6	00216	NUT, 1/2" TOP LOCK	4



120 Eastgate Drive SE  
 PO Box 7  
 Hutchinson, MN 55350

1-800-788-6483  
 1-320-587-2322  
 1-320-587-6112 (Fax)

[WWW.MAYWES.COM](http://WWW.MAYWES.COM)

## QD2 Stalk Stomper Instructions

### Safety Recommendations:

Prior to installation, removal or maintenance of May Wes Stalk Stompers, please follow the safety steps listed below, in addition to all safety recommendations listed in the OEM owner's manuals.

- Park implement on level ground and lock the brakes.
- Raise the head and lock in the upright position.
- Support all row units that stalk stompers will be installed on to ensure row units stay stationary during installation (corn head row unit mount application only).

### Setup/Operating Recommendations:

May Wes stalk stompers are intended to be setup/operated with minimal to no ground contact and minimal spring compression during field operation. To achieve the recommended operating setup, rotate spring to reduce or increase down pressure per application requirements. Minimizing spring preload will allow for maximum spring travel during operation. After operating position is established, adjust the chains so there is no slack when the shoe is not in contact with the ground. This will help reduce shoe damage, premature wear of the poly and accidental spring loss.

**Note:** As with all aftermarket product applications please maintain an awareness of the stalk stompers during operation. The head/stalk stompers should always be raised prior to backing up to prevent damage to the stalk stompers. The curved design of the shoe is intended to prevent or minimize damage if the head/stalk stompers are inadvertently left down while backing up.

### Maintenance Recommendations:

Your May Wes stalk stompers should require minimal maintenance during operation. During routine equipment maintenance, grease Stalk Stomper pivot point. Periodically check the pivot bolts connecting the shoes and the mount brackets and replace when wear is present. The springs and chains should also be checked periodically for proper adjustment/operation and to ensure the cotter pins are still in place. This should be done along with other routine maintenance of the equipment.

### Transport Recommendations:

If a header cart is used to transport head, stalk stomper shoes may need to be removed on rows that interfere with the header cart. Follow the Safety Recommendations listed above prior to beginning the recommended procedure listed below for transport. See page 2 for Transport Position (toolbar mount only).

**Note:** For ease of storage of Quick Disconnect 2 Stalk Stompers, optional Storage Brackets are available for purchase. To order Storage Brackets per pair (set of two) use part number 43020.

### Storage Recommendations:

It is recommended that stalk stompers be removed prior to storing the head. Please refer to the procedures listed under Transport Recommendations for removal of Quick Disconnect 2 stalk stompers.

**PLEASE VISIT [WWW.MAYWES.COM](http://WWW.MAYWES.COM) FOR VIDEO INSTALLATION**



120 Eastgate Drive SE  
PO Box 7  
Hutchinson, MN 55350

1-800-788-6483  
1-320-587-2322  
1-320-587-6112 (Fax)

[WWW.MAYWES.COM](http://WWW.MAYWES.COM)

## QD2 Stalk Stomper Instructions

### Operating Position

### Transporting Position

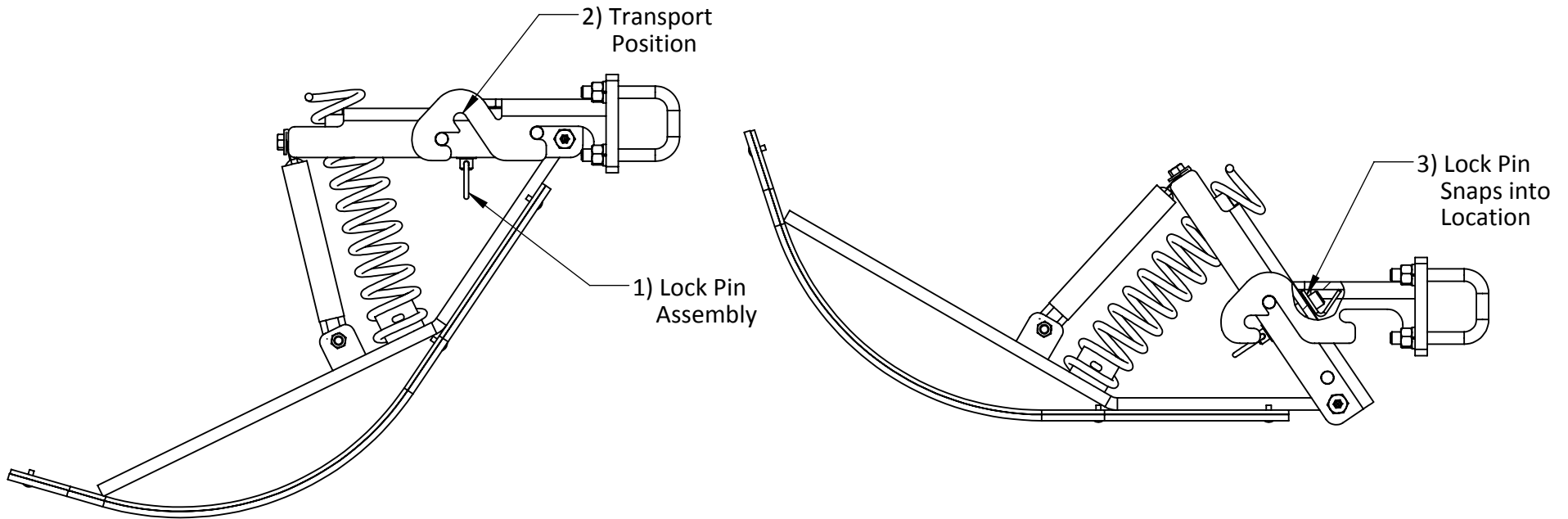

#### **Transport Position (Toolbar Mount Only):**

- 1) Pull down on Lock Pin Assembly to release Stalk Stomper Shoe
- 2) Place front mounting pin in upright position
- 3) Pull up until Lock Pin Assembly snaps into place



**MAY WES**  
*Original Poly People*  
A DIVISION OF PRIDE SOLUTIONS

120 Eastgate Drive SE  
PO Box 7  
Hutchinson, MN 55350

1-800-788-6483  
1-320-587-2322  
1-320-587-6112 (Fax)

[WWW.MAYWES.COM](http://WWW.MAYWES.COM)

## QD2 TOOLBAR MOUNT STALK STOMPER ASSEMBLY INSTRUCTIONS / PARTS LISTING

### 43000 QD2 TOOLBAR MOUNT STALK STOMPER ASSEMBLY

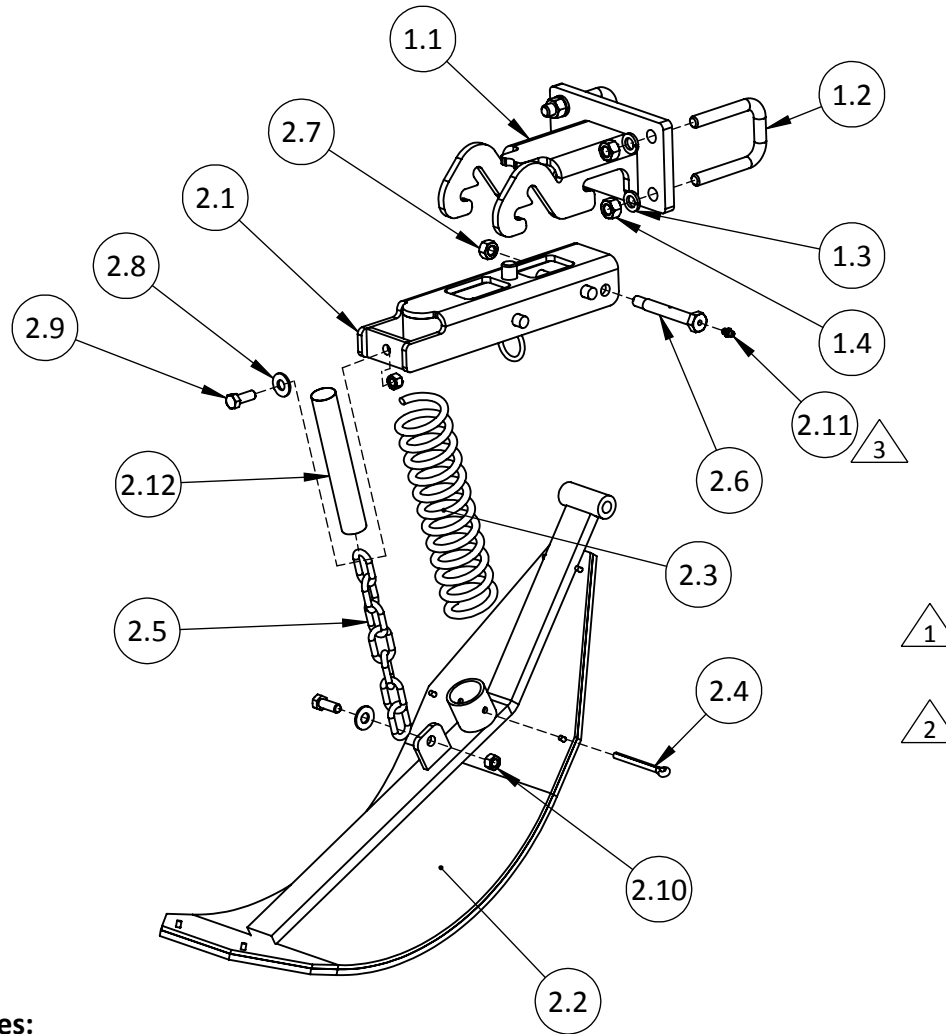

ITEM #	PART #	DESCRIPTION	QTY
1	43001	TOOLBAR MOUNT BRACKET ASSY	1
1.1	43002	TOOLBAR MOUNT BRACKET	1
1.1.3	24022	LOCK PLATE	1
1.2	00986	U-BOLT 1/2"-13	2
1.3	00255	WASHER, 1/2" SPRING LOCK	4
1.4	00214	NUT, 1/2"-13 HEX	4
2	43003	STALK STOMPER ASSY 9"	1
2.1	43004	SHOE BRACKET ASSY	1
2.2	41825	STALK STOMPER SHOE W/POLY 9"	1
2.3	01040	SPRING	1
2.4	00691	PIN, 1/4" X 3" COTTER	1
2.5	00931	CHAIN	1
2.6	01001	BOLT, CUSTOM (GREASEABLE)	1
2.7	00213	NUT, 7/16"-14 HEX TOP LOCK	1
2.8	00249	WASHER, 3/8" FLAT	2
2.9	00104	BOLT, 3/8"-16 X 1" HEX	2
2.10	00209	NUT, 3/8"-16 HEX	2
2.11	01009	GREASE FITTING, 1/4"-28 STRAIGHT	1
2.12	01046	CHAIN SLEEVE	1

**Notes:**

- △ 1 43016 - 14" Stalk Stomper Shoe Assy
- △ 2 41748 - 14" Stalk Stomper Shoe W/Poly
- △ 3 Install Self-Tapping Grease Fitting into end of Pivot Bolt  
Torque grease fitting to 65-70 inch pounds. DO NOT OVERTIGHTEN!



120 Eastgate Drive SE  
PO Box 7  
Hutchinson, MN 55350

1-800-788-6483  
1-320-587-2322  
1-320-587-6112 (Fax)

WWW.MAYWES.COM

## TOOLBAR MOUNT STALK STOMPER ASSEMBLY INSTRUCTIONS / PARTS LISTING

**41834**  
VERTICAL BRACKET  
ASSEMBLY

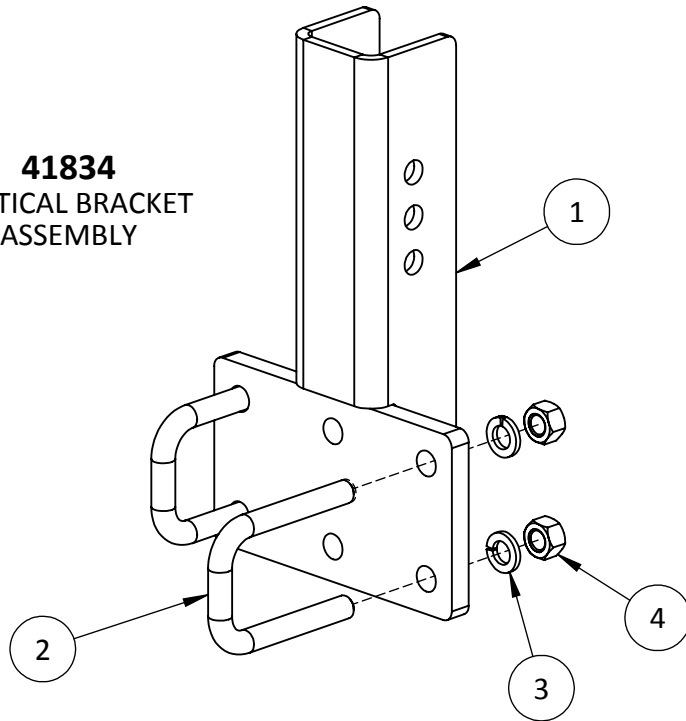

ITEM #	PART #	DESCRIPTION	QTY
1	41783	VERTICAL BRACKET	1
2	00986	U-BOLT 1/2"-13	2
3	00255	WASHER, 1/2" SPRING LOCK	4
4	00214	NUT, 1/2"-13 HEX	4

**41827**  
TOOLBAR SPLICE

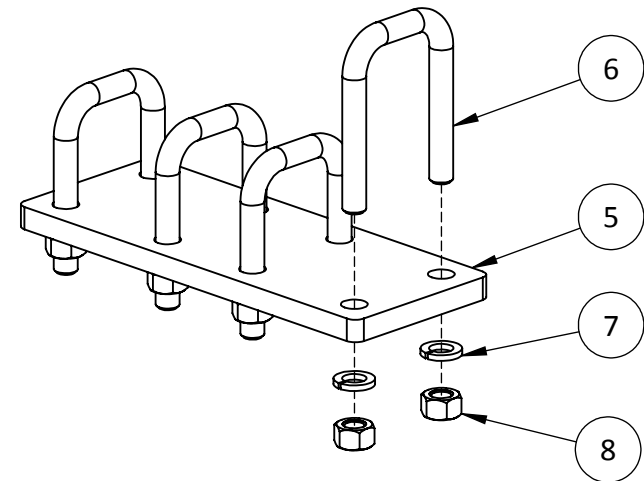

ITEM #	PART #	DESCRIPTION	QTY
5	22341	SPLICE PLATE	1
6	00986	U-BOLT 1/2"-13	4
7	00255	WASHER, 1/2" SPRING LOCK	8
8	00214	NUT, 1/2"-13 HEX	8

**Items 9 and 10 listed below (but not shown) are not included in all kits, please order individually if needed.**

ITEM #	PART #	DESCRIPTION	QTY
9	41672	72" TOOLBAR (2" X 2")	VARIABLES
10	41673	102" TOOLBAR (2" X 2")	VARIABLES



**MAY WES**  
*Original Poly People*  
A DIVISION OF PRIDE SOLUTIONS

120 Eastgate Drive SE  
PO Box 7  
Hutchinson, MN 55350

1-800-788-6483  
1-320-587-2322  
1-320-587-6112 (Fax)

[WWW.MAYWES.COM](http://WWW.MAYWES.COM)

## QD2 TOOLBAR MOUNT STALK STOMPER ASSEMBLY/INSTALLATION INSTRUCTIONS

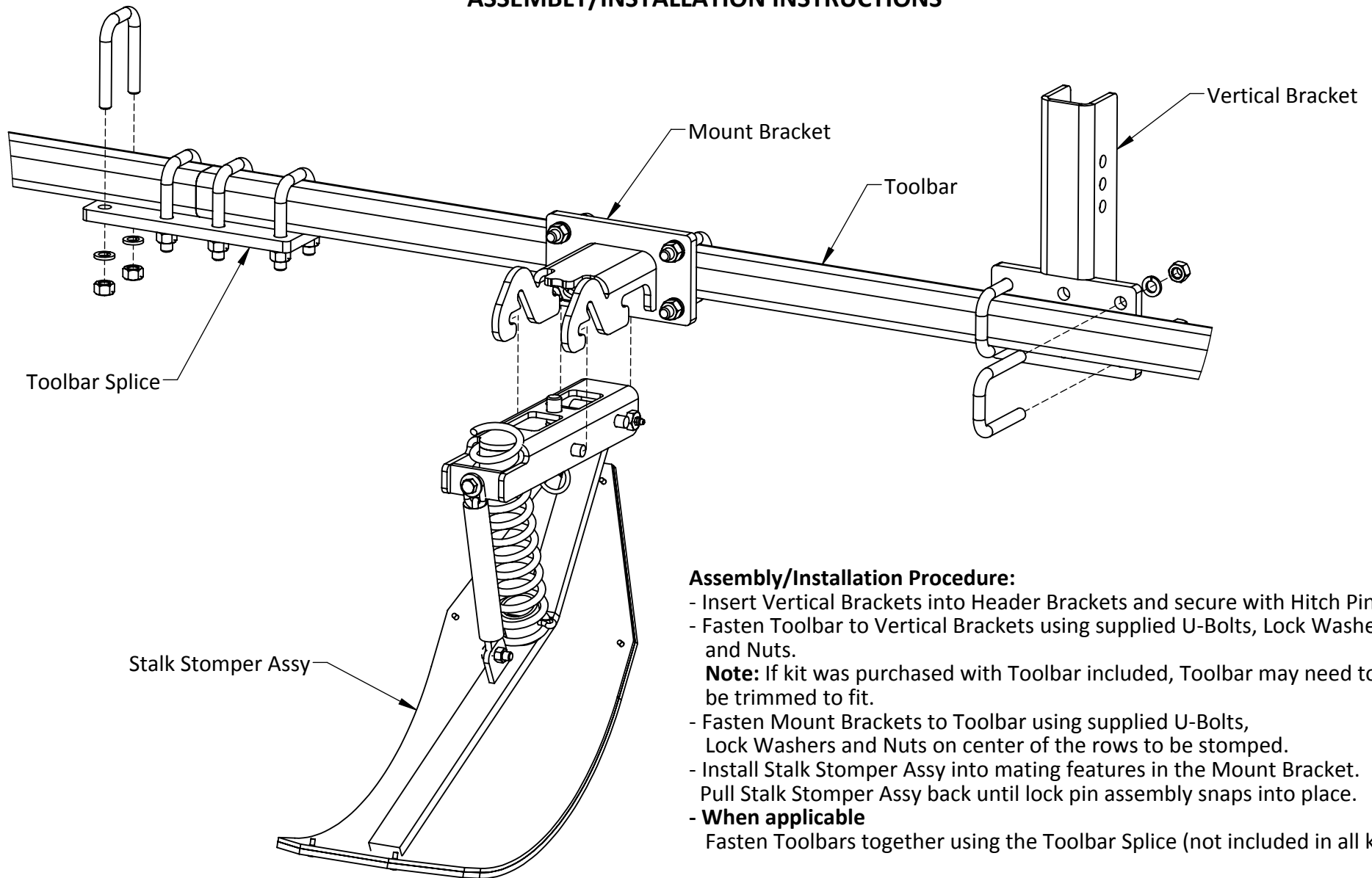

### Assembly/Installation Procedure:

- Insert Vertical Brackets into Header Brackets and secure with Hitch Pin.
- Fasten Toolbar to Vertical Brackets using supplied U-Bolts, Lock Washers and Nuts.

**Note:** If kit was purchased with Toolbar included, Toolbar may need to be trimmed to fit.

- Fasten Mount Brackets to Toolbar using supplied U-Bolts, Lock Washers and Nuts on center of the rows to be stomped.
- Install Stalk Stomper Assy into mating features in the Mount Bracket. Pull Stalk Stomper Assy back until lock pin assembly snaps into place.
- **When applicable**  
Fasten Toolbars together using the Toolbar Splice (not included in all kits).



## QD2 TOOLBAR MOUNT STALK STOMPER TRANSPORT POSITION

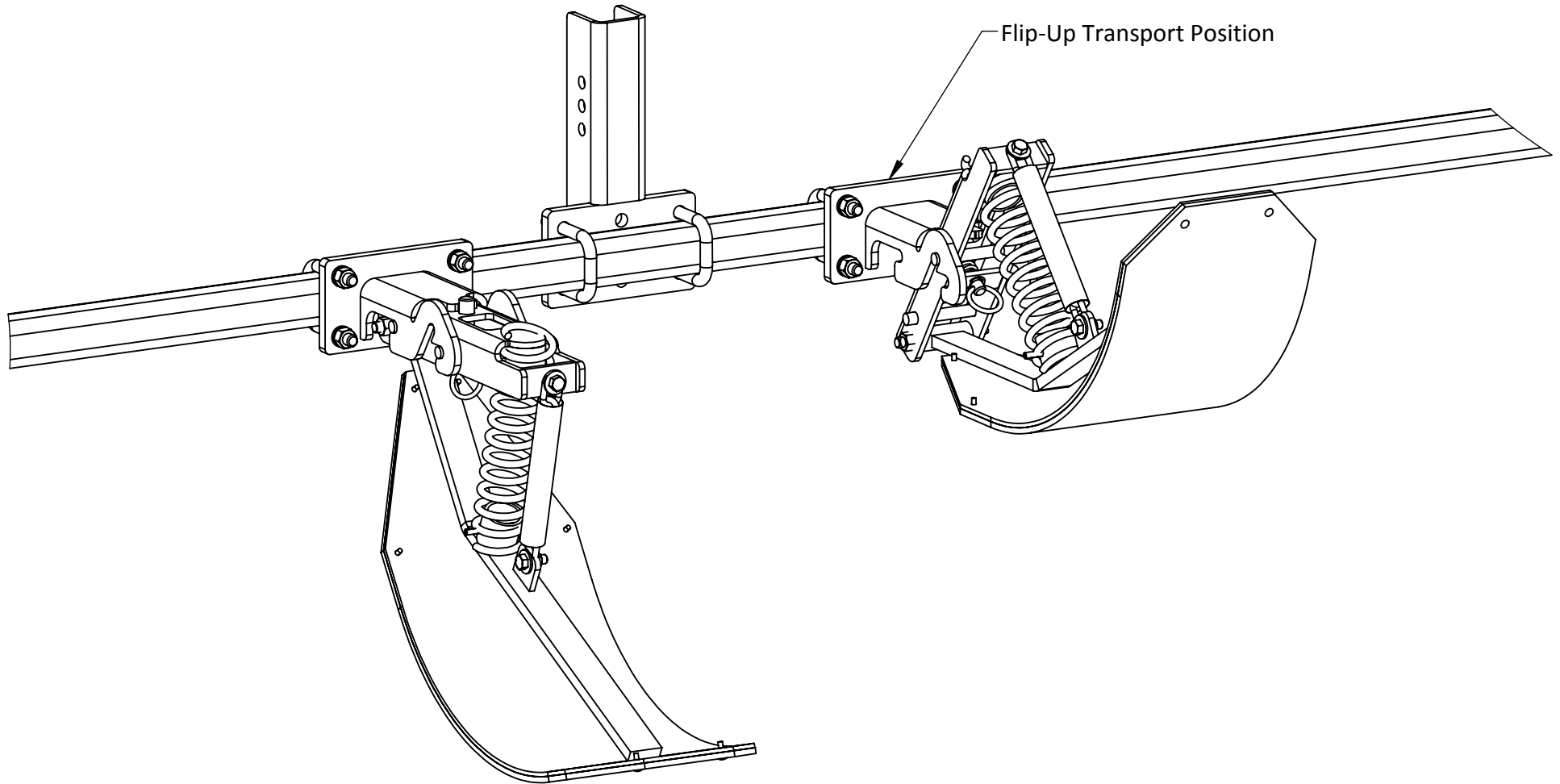

### Flip-Up Transport Position (Toolbar Mount Only):

- 1) Pull down on Lock Pin Assembly to release Stalk Stomper Shoe
- 2) Place front mounting pin in upright position
- 3) Pull up until Lock Pin Assembly snaps into place



**MAY WES**  
*Original Poly People*  
A DIVISION OF PRIDE SOLUTIONS

120 Eastgate Drive SE  
PO Box 7  
Hutchinson, MN 55350

1-800-788-6483  
1-320-587-2322  
1-320-587-6112 (Fax)

[WWW.MAYWES.COM](http://WWW.MAYWES.COM)

## QD2 TOOLBAR MOUNT STALK STOMPER OPTIONAL SETUPS

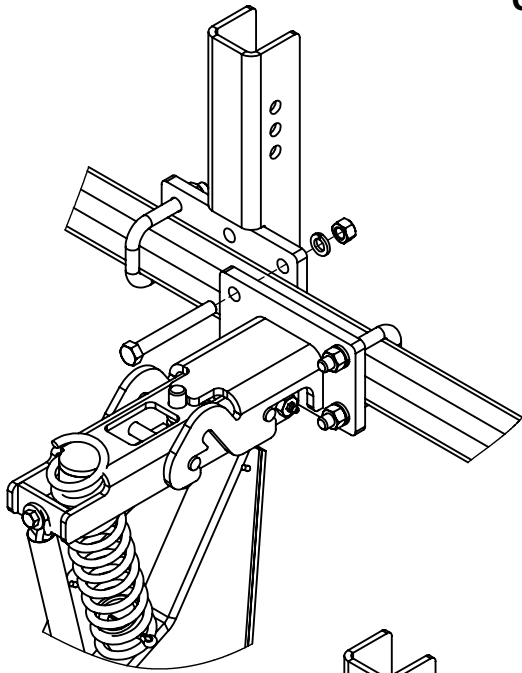

### Overlapping Brackets

If necessary, Mount Brackets and Vertical Brackets can be overlapped in multiple positions to allow the Stalk Stomper Assy to be positioned on center of the row. Replace U-Bolts with 1/2"-13 x 4" Hex Bolts (not supplied) as shown on the left.

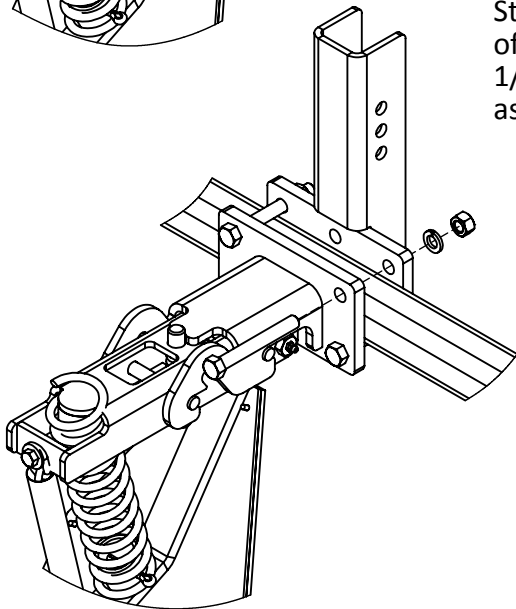

### Offsetting Toolbars

If necessary, the Toolbars may be offset in any direction by positioning Toolbars on opposite sides of the Toolbar Splice as shown below.

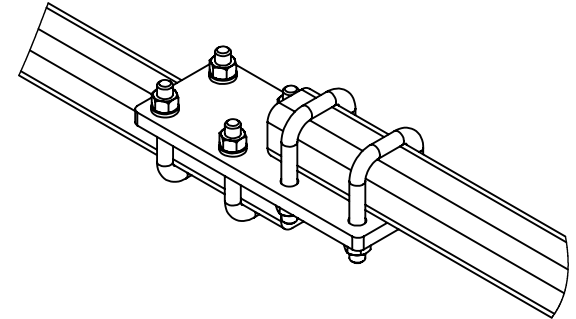

### Toolbar Splice Orientation

The Toolbar Splice Plate can be positioned on the bottom, top, front or back (shown below) of the Toolbars to provide the most rigidity per individual setup.

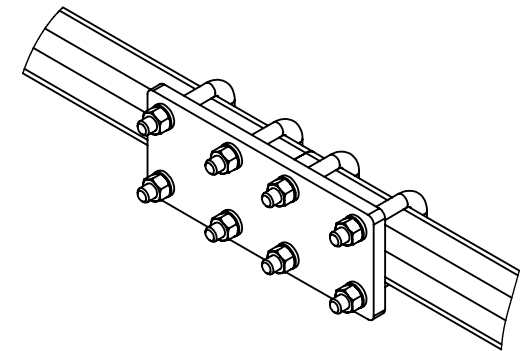

120 Eastgate Drive SE  
PO Box 7  
Hutchinson, MN 55350

1-800-788-6483  
1-320-587-2322  
1-320-587-6112 (Fax)

[WWW.MAYWES.COM](http://WWW.MAYWES.COM)