

G4 Stalk Stomper Instructions

Safety Recommendations:

Prior to installation, removal or maintenance of May Wes Stalk Stompers, please follow the safety steps listed below, in addition to all safety recommendations listed in the OEM owner's manuals.

- Park implement on level ground and lock the brakes.
- Raise the head and lock in the upright position.
- Support all row units that stalk stompers will be installed on to ensure row units stay stationary during installation (corn head row unit mount application only).

Setup/Operating Recommendations:

May Wes stalk stompers are intended to be setup/operated with minimal to no ground contact and minimal spring pressure during field operation. To achieve the recommended operating setup, with the combine parked on a hard, level surface lower the head to field operating height. With the head at operating height, the stalk stompers should be 1 to 2 inches above the ground.

Note: As with all aftermarket product applications please maintain an awareness of the stalk stompers during operation. The head/stalk stompers should always be raised prior to backing up to prevent damage to the stalk stompers. The curved design of the shoe is intended to prevent or minimize damage if the head/stalk stompers are inadvertently left down while backing up.

Maintenance Recommendations:

Your May Wes G4 stalk stompers should require minimal maintenance during operation. During routine equipment maintenance, visually inspect the stalk stompers and mounting brackets for any damaged parts and repair or replace as necessary. Check all mounting hardware to ensure tightness and retighten if necessary.

Transport Recommendations:

If a header cart is used to transport head, stalk stomper shoes may need to be removed on rows that interfere with the header cart. Follow the Safety Recommendations listed above prior to beginning the recommended procedure listed below for transport. See page 2 for Transport Position (toolbar mount only).

Storage Recommendations:

To prevent damage, it is recommended that stalk stompers be removed prior to storing the head.



120 Eastgate Drive SE
Hutchinson, MN 55350

1-800-788-6483
1-320-587-2322
1-320-587-6112 (Fax)

WWW.MAYWES.COM

G4 Stalk Stomper Instructions

OPERATING POSITION

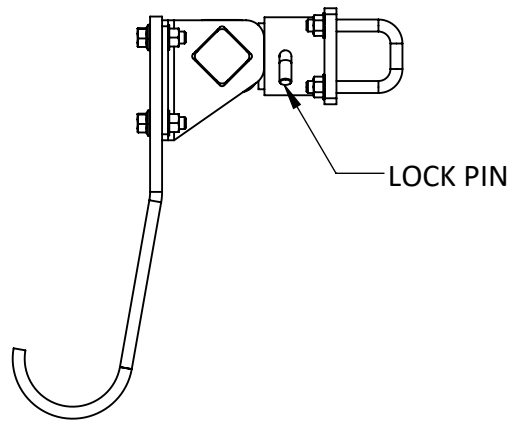

TRANSPORT POSITION

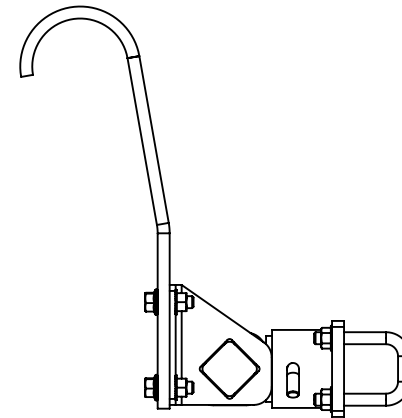

Transport Position (Toolbar Mount Only):

- 1) Remove lock pin to rotate stalk stomper to 90, 180 or 270 degree position
- 2) Replace lock pin to secure stalk stomper



MAY WES
Original Poly People
A DIVISION OF PRIDE SOLUTIONS

120 Eastgate Drive SE
Hutchinson, MN 55350

1-800-788-6483
1-320-587-2322
1-320-587-6112 (Fax)

WWW.MAYWES.COM

CASE IH 2200/2400/3200/3400 - NEW HOLLAND 96C/96D/98C/98D/996
G4 STALK STOMPER PARTS LISTING/ASSEMBLY INSTRUCTIONS

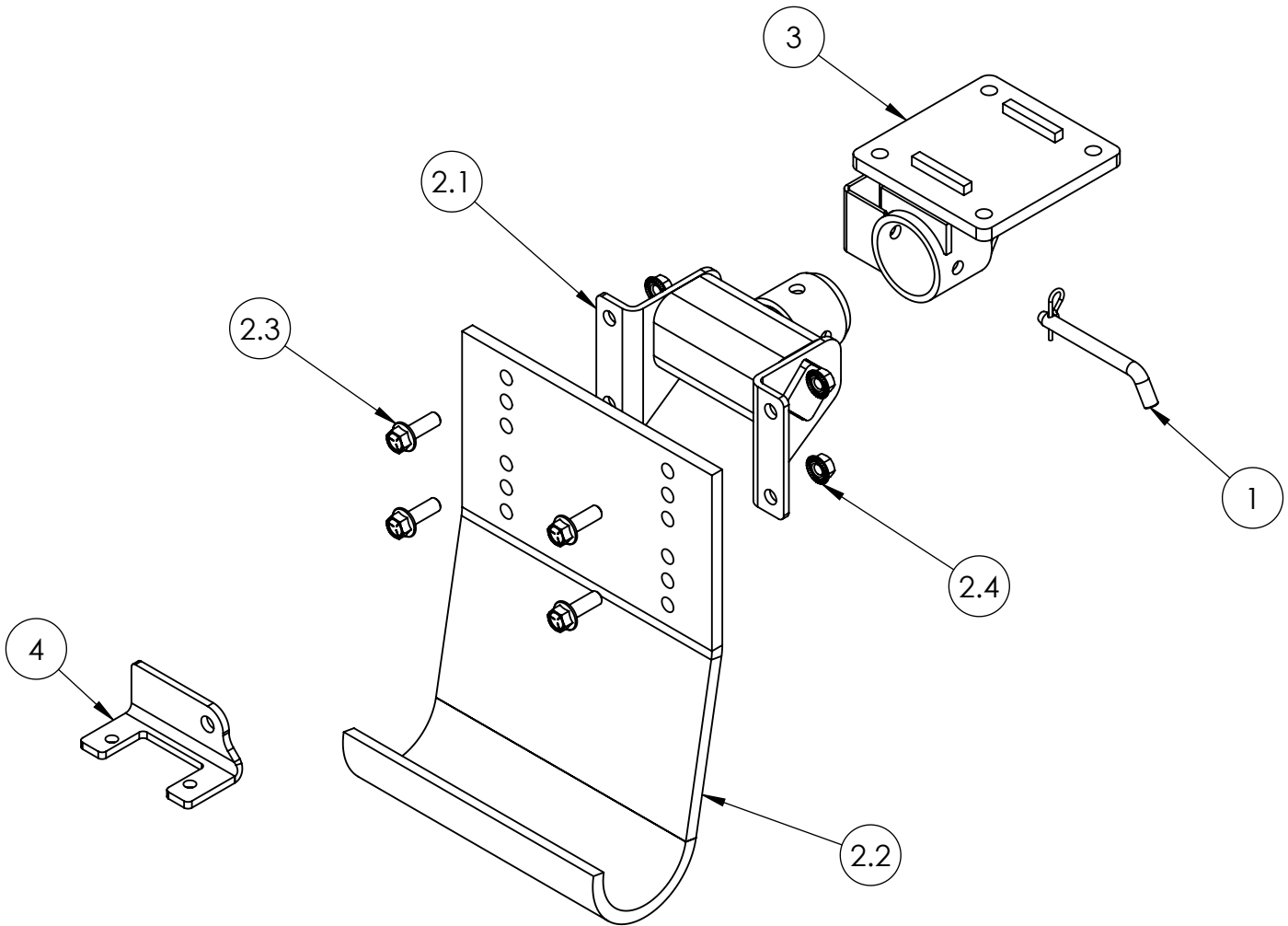

NOTES:

△ 1 Item 4 is optional and not included in the kit, please order separately

ITEM #	PART #	DESCRIPTION	QTY
1	01130	PIN, 1/2" X 4" BENT HITCH	1
2.1	42295	STALK STOMPER TORSION ASSY	1
2.2	22726	SHOE, STALK STOMPER	1
2.3	00729	BOLT, 1/2"-13 X 1-1/2" HEX FLANGE	4
2.4	00730	NUT, 1/2"-13 HEX FLANGE	4
3	42353	HEADER BRACKET	1
4	22043	MOUNT BRACKET (OPTIONAL)	



MAY WES
Original Poly People
 A DIVISION OF PRIDE SOLUTIONS

**120 Eastgate Drive SE
 Hutchinson, MN 55350**

**1-800-788-6483
 1-320-587-2322
 1-320-587-6112 (Fax)**

WWW.MAYWES.COM

CASE IH 2200/2400/3200/3400 - NEW HOLLAND 96C/96D/98C/98D/996 STALK STOMPER INSTALLATION

Safety Procedure:

- Park combine on level ground and engage the parking brake.
- Raise the head and lock in the upright position.
- Support all row units that stalk stompers will be installed on to ensure row units remain stationary during installation.

Installation Procedure:

- Remove the factory gearbox support brackets (Fig. 1). Replace with Header Bracket (42353) positioning the mount plate as pictured below in Figure 2.
- **Note:** If installing stalk stomper on the same row that the deck plate cylinder is attached; replace the factory mounting bracket with Mount Bracket (22043) which is not included in the kit, please order separately (Fig. 3).
- Insert the Stalk Stomper Assy (43100) into mating feature in the Header Bracket (42353). Insert lock pin to secure stomper assy in place.

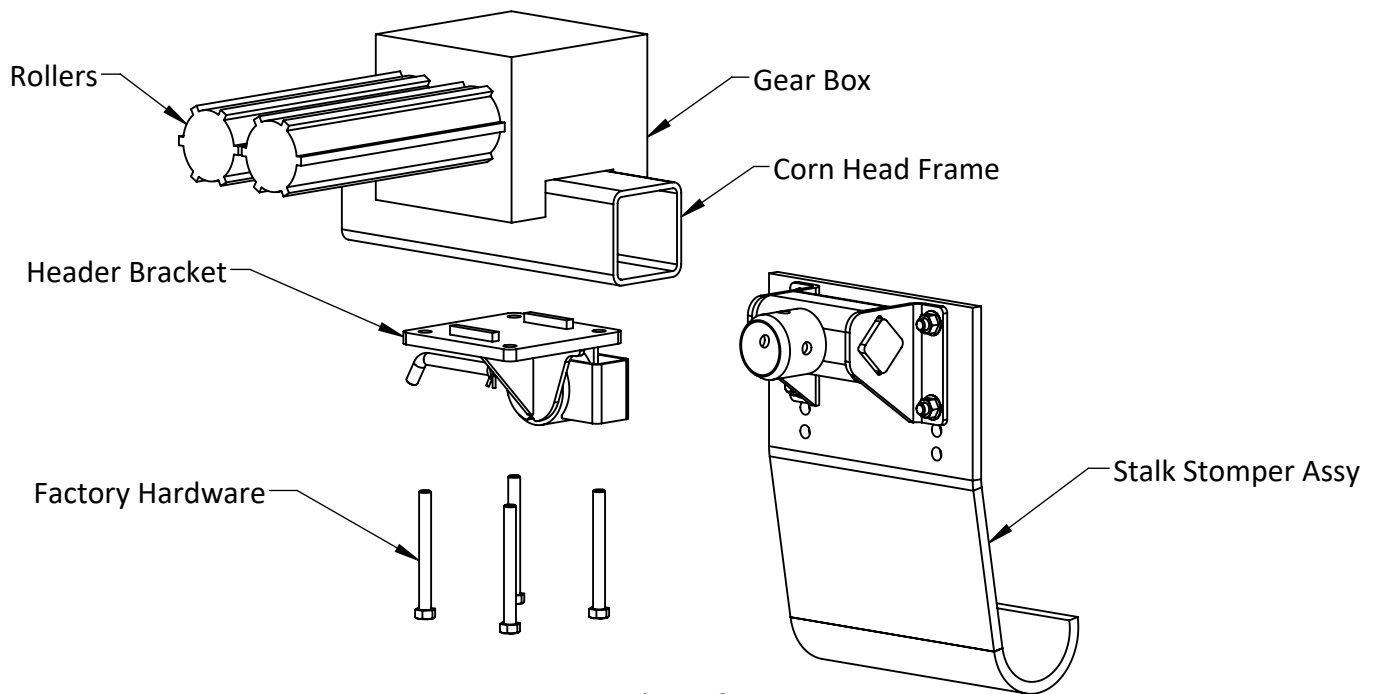

Figure 2

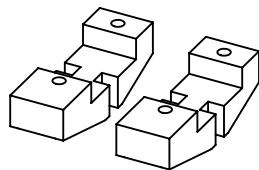

Figure 1
Gear Box
Support Brackets

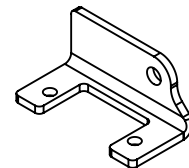

Figure 3
Deck Plate
Mount Bracket
(Optional)