

# CASE IH 2200/2400/3200/3400 SERIES - NEW HOLLAND 96C/98C/980D/996 G4 TOOLBAR MOUNT STALK STOMPER

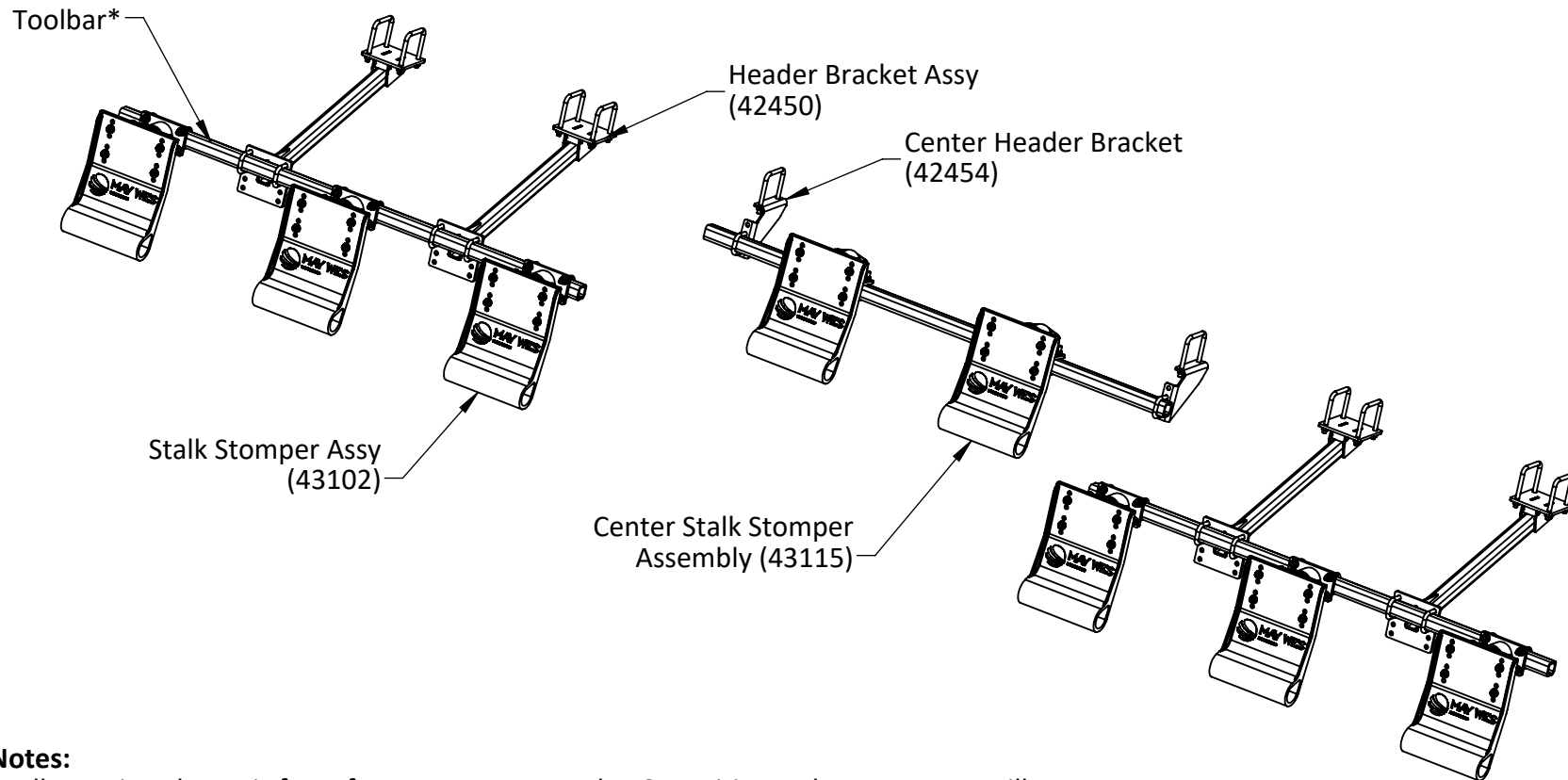

**Notes:**

- Illustration shown is for reference purposes only. Quantities and components will vary. Please refer to individual component parts listings for specific information.

\* Toolbar is not included in all kits. If a kit without Toolbar was ordered, the customer is responsible for providing required Toolbar.



120 Eastgate Drive SE  
Hutchinson, MN 55350

1-800-788-6483  
1-320-587-2322  
1-320-587-6112 (Fax)

WWW.MAYWES.COM

# CASE IH 2200/2400/3200/3400 SERIES - NEW HOLLAND 96C/98C/980D/996 G4 TOOLBAR MOUNT STALK STOMPER

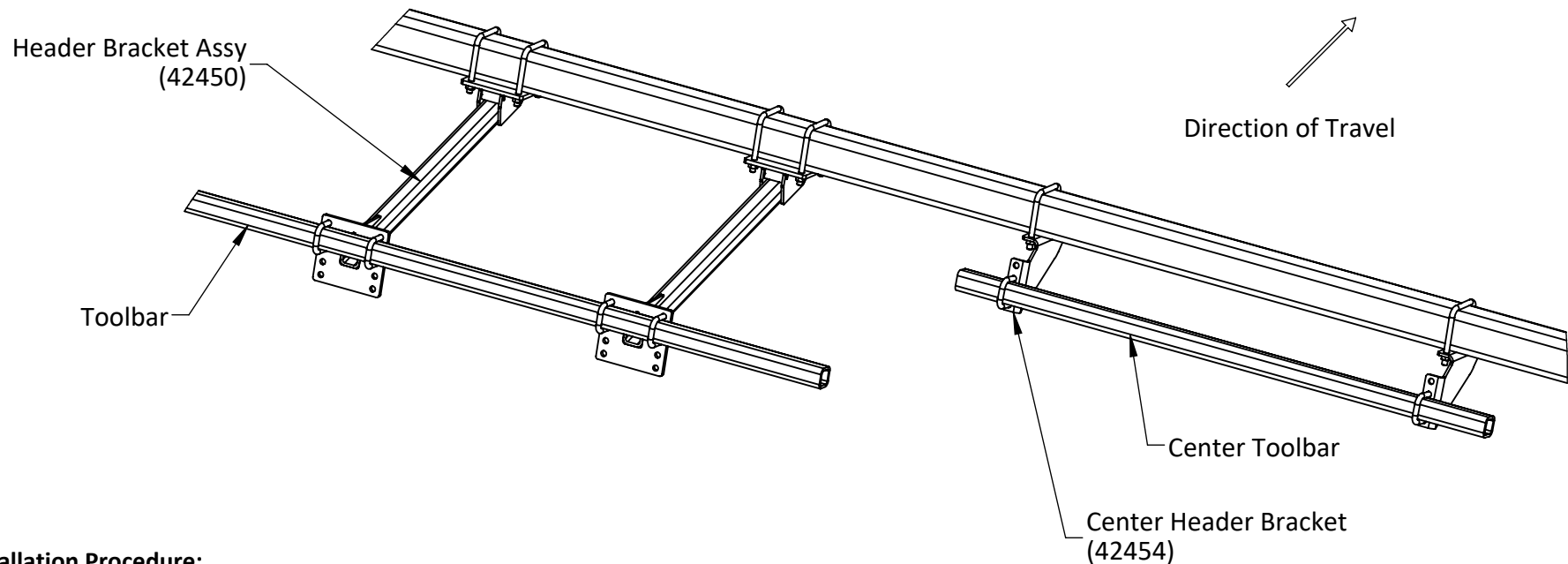

## Installation Procedure:

- Park combine on level ground and lock the brakes.
- Raise the head and lock in the upright position.
- Mount the Header Brackets to the 4" x 4" frame beam on the bottom of the corn head. Place the U-Bolts over the top of the 4 x 4 frame beam.
- Place the Header Bracket Assembly (42450) below the 4 x 4 frame tube and between the row units.
- Mount two Header Brackets on each side of the head, positioning the brackets where needed while keeping as much distance between them as possible.
- Mount Center Header Brackets (42454) to the 4" x 4" frame beam on the bottom of the corn head. Place the U-Bolts over the top of the 4 x 4 frame beam.
- Mount toolbar (2" x 2" square tube) to the mounting brackets using the 2" U-Bolts and lock nuts provided.

**Note:** Toolbars may need to be trimmed to fit.



**MAY WES**  
*Original Poly People*  
A DIVISION OF PRIDE SOLUTIONS

120 Eastgate Drive SE  
Hutchinson, MN 55350

1-800-788-6483  
1-320-587-2322  
1-320-587-6112 (Fax)

[WWW.MAYWES.COM](http://WWW.MAYWES.COM)

# CASE IH 2200/2400/3200/3400 SERIES - NEW HOLLAND 96C/98C/980D/996 G4 TOOLBAR MOUNT STALK STOMPER

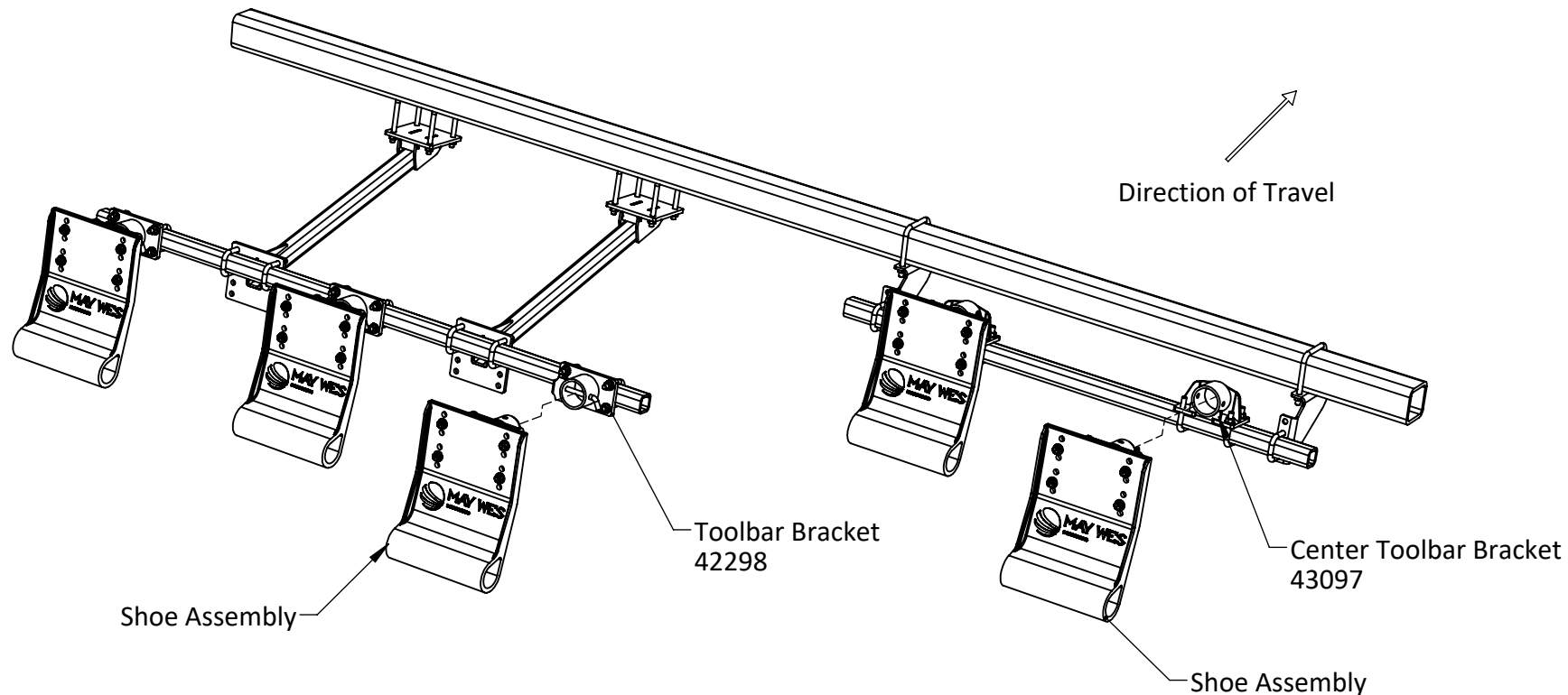

## Installation Procedure:

- On flat ground, lower the head to approximate working height.
- Attach Toolbar Brackets using U-Bolts and nuts, behind the center of each row to be stomped.
- Lift Stalk Stomper Assembly into mating features on the mounting bracket and attach with pin and clip.
- Height can be adjusted by repositioning the shoe to the torsion unit. Each hole set will adjust the height by 1"

## NOTE:

Refer to G4 Stalk Stomper Instruction (Document 10274) for Setup, Operation, Maintenance, Transport and Storage Instructions



120 Eastgate Drive SE  
Hutchinson, MN 55350

1-800-788-6483  
1-320-587-2322  
1-320-587-6112 (Fax)

[WWW.MAYWES.COM](http://WWW.MAYWES.COM)

**CASE IH 2200/2400/3200/3400 SERIES - NEW HOLLAND 96C/98C/980D/996  
G4 TOOLBAR MOUNT STALK STOMPER**

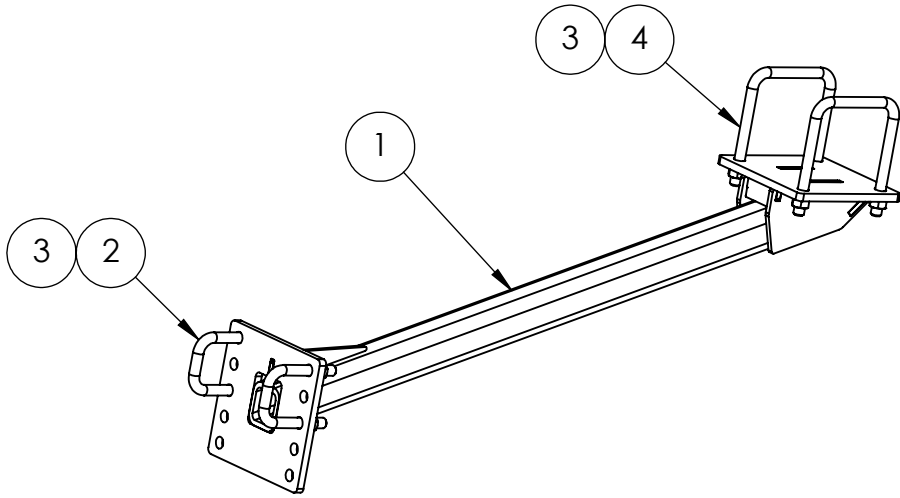

**42450 - Header Bracket Assembly**

4	00965	U-BOLT 1/2"-13 x 4"	2
3	00730	NUT, 1/2"-13 HEX FLANGE	8
2	00986	U-BOLT 1/2"-13 X 2"	2
1	42449	ARM, CIH 22/24/32/34 MOUNT	1
ITEM #	PART #	DESCRIPTION	QTY.

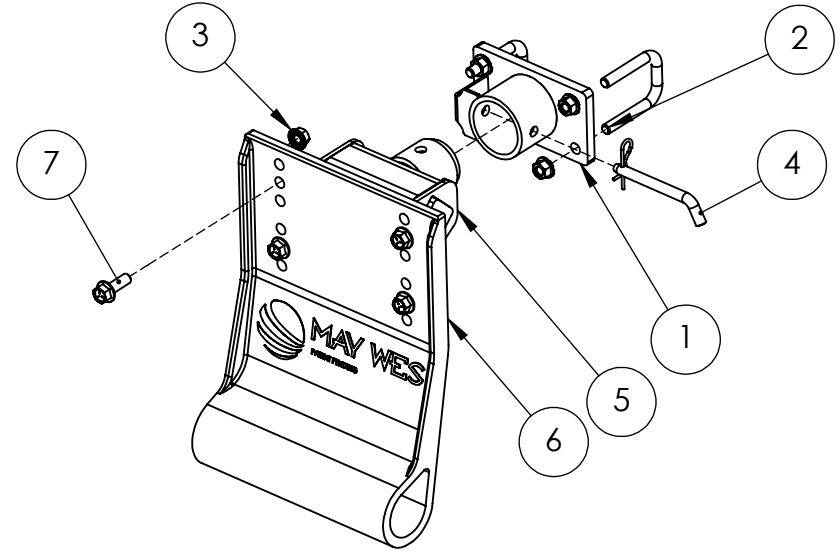

**43102 - Stalk Stomper Shoe Assembly**

7	00729	BOLT, 1/2"-13 X 1-1/2" HEX FLANGE	4
6	24100	SHOE, G4 MOLDED	1
5	42295	STALK STOMPER TORSION ASSY	1
4	01130	PIN, 1/2" X 4" BENT HITCH	1
3	00730	NUT, 1/2"-13 HEX FLANGE	8
2	00986	U-BOLT 1/2"-13 X 2"	2
1	42298	WLDMT; TOOLBAR MNT BRKT	1
ITEM #	PART #	DESCRIPTION	QTY.



120 Eastgate Drive SE  
Hutchinson, MN 55350

1-800-788-6483  
1-320-587-2322  
1-320-587-6112 (Fax)

[WWW.MAYWES.COM](http://WWW.MAYWES.COM)

# CASE IH 2200/2400/3200/3400 SERIES - NEW HOLLAND 96C/98C/980D/996 G4 TOOLBAR MOUNT STALK STOMPER

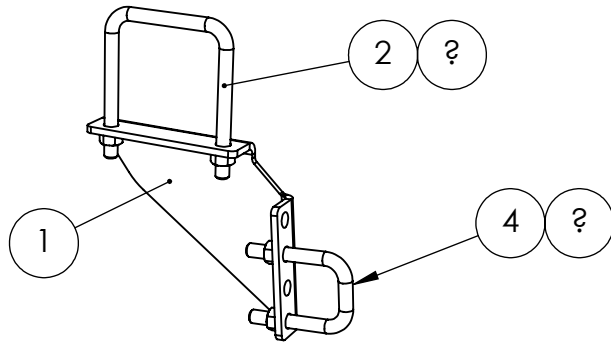

## 42454 - Center Header Bracket Assembly

5	00216	NUT, 1/2" NC TOP LOCK	2
4	00986	U-BOLT 1/2"-13 X 2"	1
3	00730	NUT, 1/2"-13 HEX FLANGE	2
2	00965	U-BOLT 1/2"-13 x 4"	1
1	22987	BRACKET, CIH 22/24/32/34 CTR	1
ITEM #	PART #	DESCRIPTION	QTY.

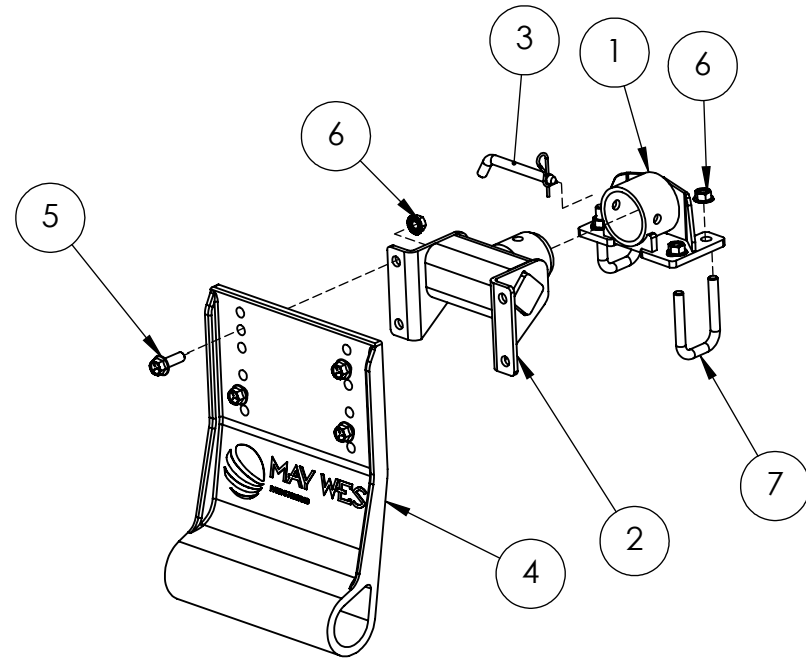

## 43115 - Stalk Stomper Shoe Assembly

7	00986	U-BOLT 1/2"-13 X 2"	2
6	00730	NUT, 1/2"-13 HEX FLANGE	8
5	00729	BOLT, 1/2"-13 X 1-1/2" HEX FLANGE	4
4	24100	SHOE, G4 MOLDED	1
3	01130	PIN, 1/2" X 4" BENT HITCH	1
2	42295	STALK STOMPER TORSION ASSY	1
1	43097	TOOLBAR MOUNT BRACKET	1
ITEM #	PART #	DESCRIPTION	QTY.



120 Eastgate Drive SE  
Hutchinson, MN 55350

1-800-788-6483  
1-320-587-2322  
1-320-587-6112 (Fax)

WWW.MAYWES.COM