

# CASE IH 2600/4200/4400 SERIES - NEW HOLLAND 99C/980 SERIES QD2 STALK STOMPER PARTS LISTING/ASSEMBLY INSTRUCTIONS

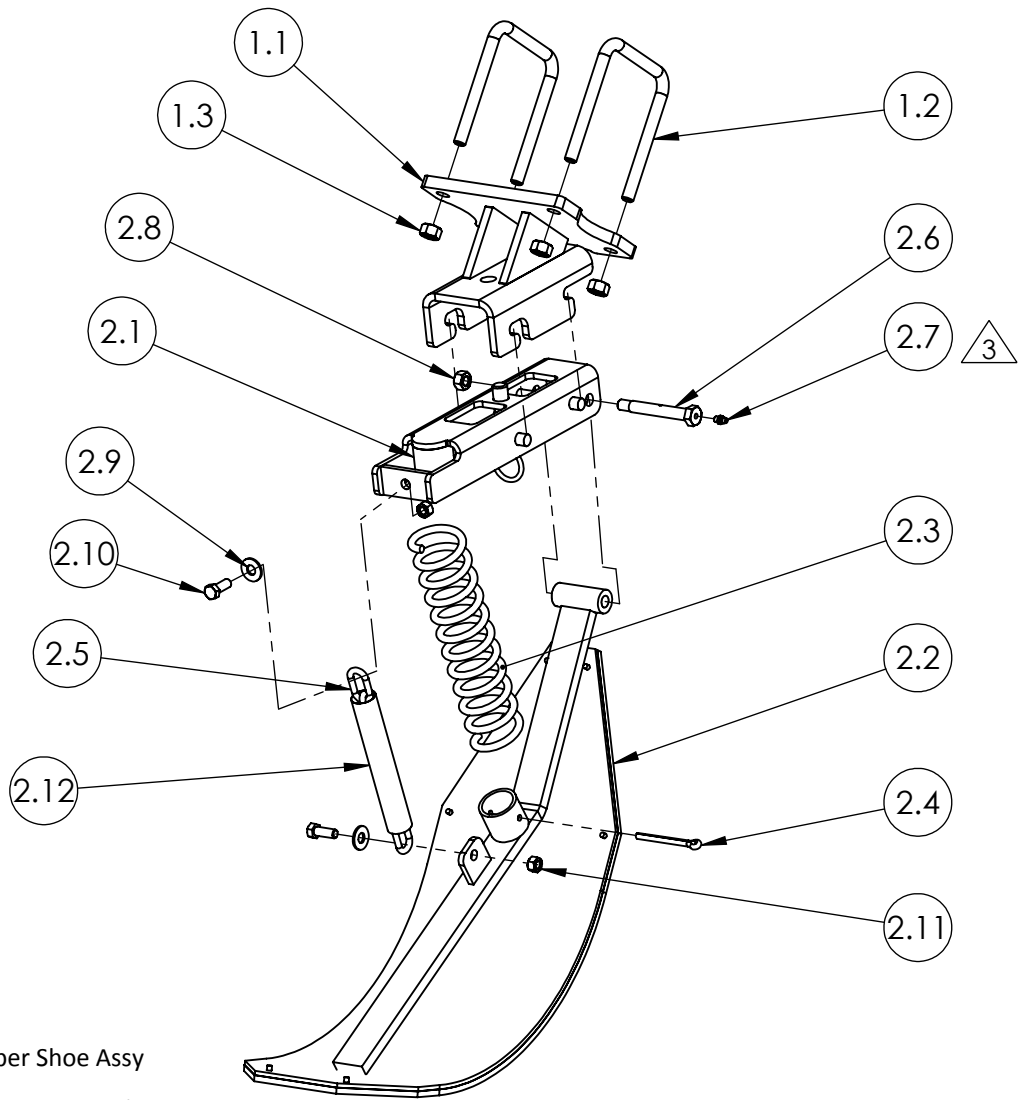

**NOTES:**

- △ 1 43016 - 14" Stalk Stomper Shoe Assy
- △ 2 41748 - 14" Stalk Stomper Shoe W/Poly
- △ 3 Install Self-Tapping Grease Fitting into end of Pivot Bolt  
Torque grease fitting to 65-70 inch pounds. DO NOT OVERTIGHTEN!

| ITEM #  | PART # | DESCRIPTION                  | QTY | ITEM # | PART # | DESCRIPTION                      | QTY |
|---------|--------|------------------------------|-----|--------|--------|----------------------------------|-----|
| 1       | 43006  | QD2 HEADER BRACKET ASSY      | 1   | 2.5    | 00931  | CHAIN                            | 1   |
| 1.1     | 43007  | QD2 HEADER BRACKET           | 1   | 2.6    | 01001  | BOLT, CUSTOM (GREASEABLE)        | 1   |
| 1.2     | 00965  | U-BOLT 1/2-13                | 2   | 2.7    | 01009  | GREASE FITTING, 1/4"-28 STRAIGHT | 1   |
| 1.3     | 00216  | NUT, 1/2"-13 TOP LOCK        | 4   | 2.8    | 00213  | NUT, 7/16"-14 HEX TOP LOCK       | 1   |
| △ 1 2   | 43003  | STALK STOMPER ASSY 9"        | 1   | 2.9    | 00249  | WASHER, 3/8" FLAT                | 2   |
| 2.1     | 43004  | SHOE BRACKET ASSY            | 1   | 2.10   | 00104  | BOLT, 3/8"-16 X 1" HEX           | 2   |
| △ 2 2.2 | 41825  | STALK STOMPER SHOE W/POLY 9" | 1   | 2.11   | 00209  | NUT, 3/8"-16 HEX                 | 2   |
| 2.3     | 01040  | SPRING                       | 1   | 2.12   | 01046  | CHAIN SLEEVE                     | 1   |
| 2.4     | 00691  | PIN, 1/4" X 3" COTTER        | 1   |        |        |                                  |     |



**120 Eastgate Drive SE  
PO Box 7  
Hutchinson, MN 55350**

**1-800-788-6483  
1-320-587-2322  
1-320-587-6112 (Fax)**

**WWW.MAYWES.COM**

# CASE IH 2600/4200/4400 SERIES - NEW HOLLAND 99C/980 SERIES

## STALK STOMPER INSTALLATION

### Safety Procedure:

- Park combine on level ground and lock the brakes.
- Raise the head and lock in the upright position.

### Installation Procedure:

- Remove the factory metal shield above the 4X4 frame beam on rows that stalk stompers are being installed.
- Place U-Bolts over the top of the 4X4 frame beam (as shown).
- Place the Header Bracket (43007) below the 4X4 frame beam on center with the row unit positioning the "hook slots" toward the rear of the head. Align the U-Bolts with Header Bracket and secure in place with the 1/2" top lock nuts, clamping the frame beam.
- Lift the Stalk Stomper Assy (43003) into mating features in the Header Bracket (43007). Pull Stalk Stomper Assy back until lock pin snaps into place.
- Replace the factory metal shield.

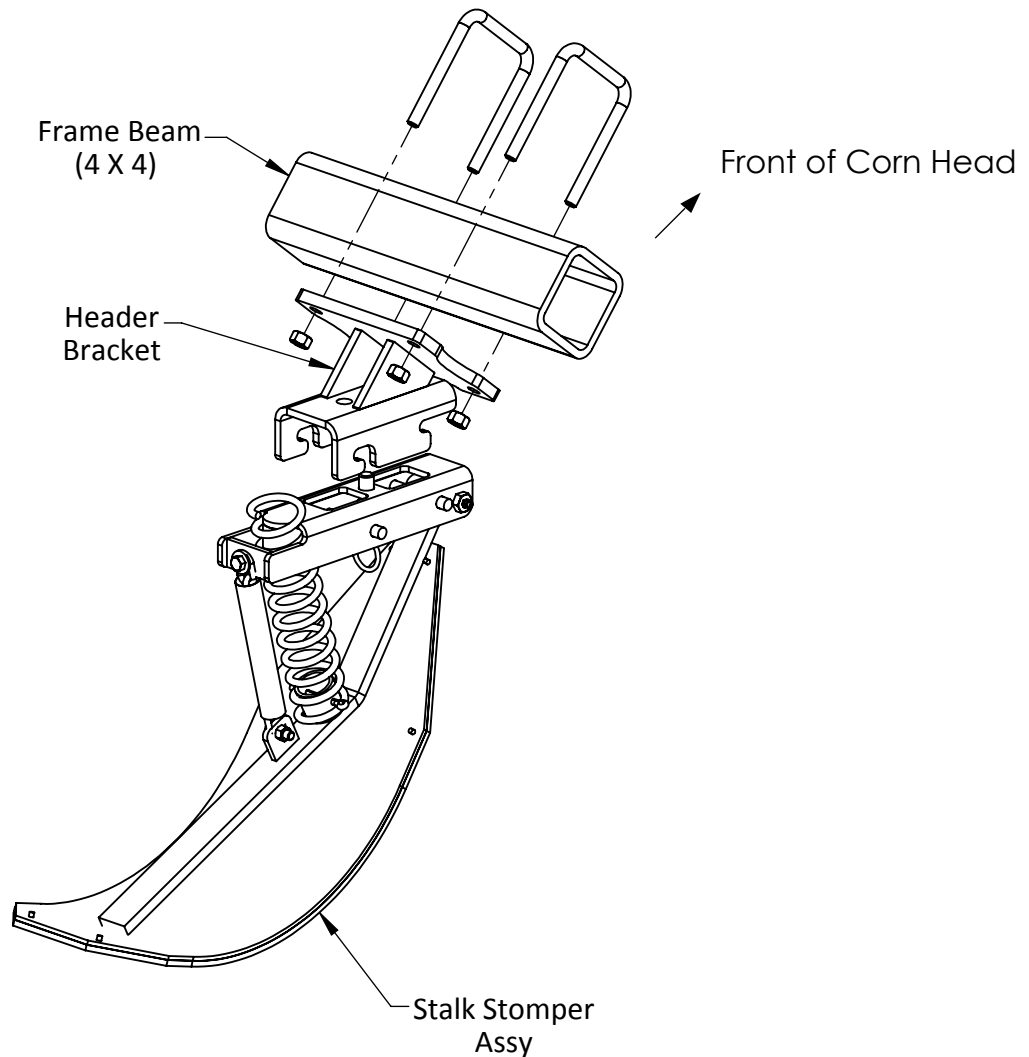

120 Eastgate Drive SE  
PO Box 7  
Hutchinson, MN 55350

1-800-788-6483  
1-320-587-2322  
1-320-587-6112 (Fax)

[WWW.MAYWES.COM](http://WWW.MAYWES.COM)

## QD2 Stalk Stomper Instructions

### Safety Recommendations:

Prior to installation, removal or maintenance of May Wes Stalk Stompers, please follow the safety steps listed below, in addition to all safety recommendations listed in the OEM owner's manuals.

- Park implement on level ground and lock the brakes.
- Raise the head and lock in the upright position.
- Support all row units that stalk stompers will be installed on to ensure row units stay stationary during installation (corn head row unit mount application only).

### Setup/Operating Recommendations:

May Wes stalk stompers are intended to be setup/operated with minimal to no ground contact and minimal spring compression during field operation. To achieve the recommended operating setup, rotate spring to reduce or increase down pressure per application requirements. Minimizing spring preload will allow for maximum spring travel during operation. After operating position is established, adjust the chains so there is no slack when the shoe is not in contact with the ground. This will help reduce shoe damage, premature wear of the poly and accidental spring loss.

**Note:** As with all aftermarket product applications please maintain an awareness of the stalk stompers during operation. The head/stalk stompers should always be raised prior to backing up to prevent damage to the stalk stompers. The curved design of the shoe is intended to prevent or minimize damage if the head/stalk stompers are inadvertently left down while backing up.

### Maintenance Recommendations:

Your May Wes stalk stompers should require minimal maintenance during operation. During routine equipment maintenance, grease Stalk Stomper pivot point. Periodically check the pivot bolts connecting the shoes and the mount brackets and replace when wear is present. The springs and chains should also be checked periodically for proper adjustment/operation and to ensure the cotter pins are still in place. This should be done along with other routine maintenance of the equipment.

### Transport Recommendations:

If a header cart is used to transport head, stalk stomper shoes may need to be removed on rows that interfere with the header cart. Follow the Safety Recommendations listed above prior to beginning the recommended procedure listed below for transport. See page 2 for Transport Position (toolbar mount only).

**Note:** For ease of storage of Quick Disconnect 2 Stalk Stompers, optional Storage Brackets are available for purchase. To order Storage Brackets per pair (set of two) use part number 43020.

### Storage Recommendations:

It is recommended that stalk stompers be removed prior to storing the head. Please refer to the procedures listed under Transport Recommendations for removal of Quick Disconnect 2 stalk stompers.

**PLEASE VISIT [WWW.MAYWES.COM](http://WWW.MAYWES.COM) FOR VIDEO INSTALLATION**



120 Eastgate Drive SE  
PO Box 7  
Hutchinson, MN 55350

1-800-788-6483  
1-320-587-2322  
1-320-587-6112 (Fax)

**WWW.MAYWES.COM**

## QD2 Stalk Stomper Instructions

### Operating Position

### Transporting Position

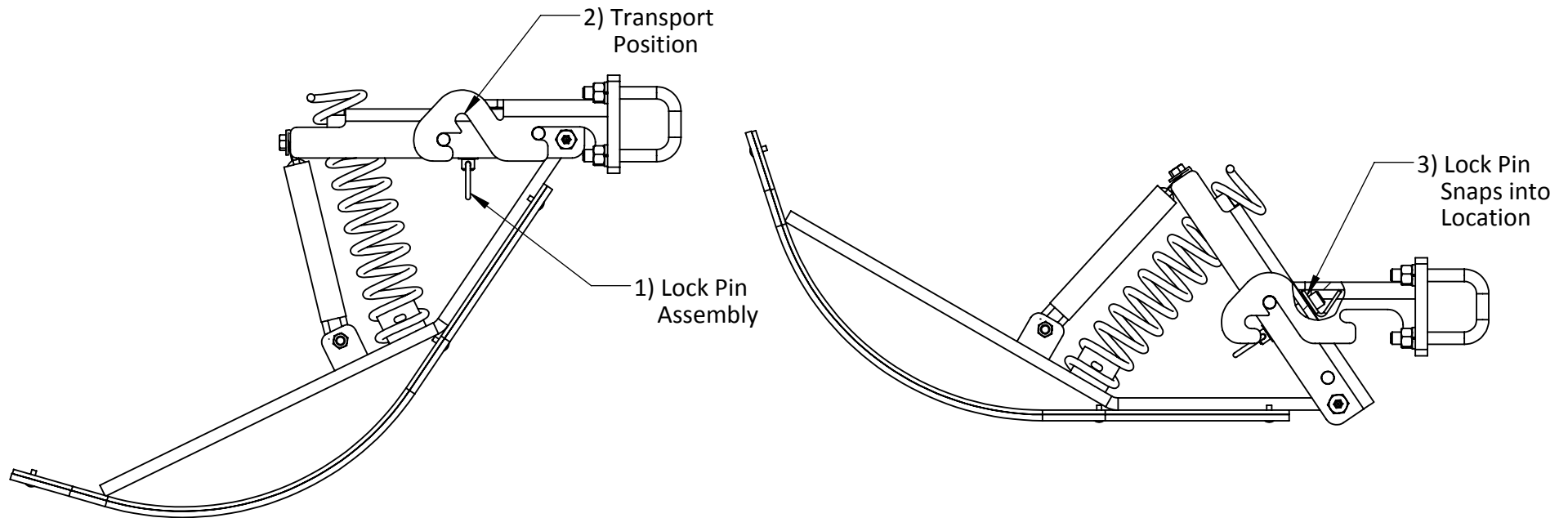

### **Transport Position (Toolbar Mount Only):**

- 1) Pull down on Lock Pin Assembly to release Stalk Stomper Shoe
- 2) Place front mounting pin in upright position
- 3) Pull up until Lock Pin Assembly snaps into place



120 Eastgate Drive SE  
PO Box 7  
Hutchinson, MN 55350

1-800-788-6483  
1-320-587-2322  
1-320-587-6112 (Fax)

[WWW.MAYWES.COM](http://WWW.MAYWES.COM)

**CASE IH 2600 SERIES - NEW HOLLAND 99C SERIES**  
**ROWS 2 & 5 ON A 6 ROW HEAD**  
**STALK STOMPER PARTS LISTING/ASSEMBLY INSTRUCTIONS**

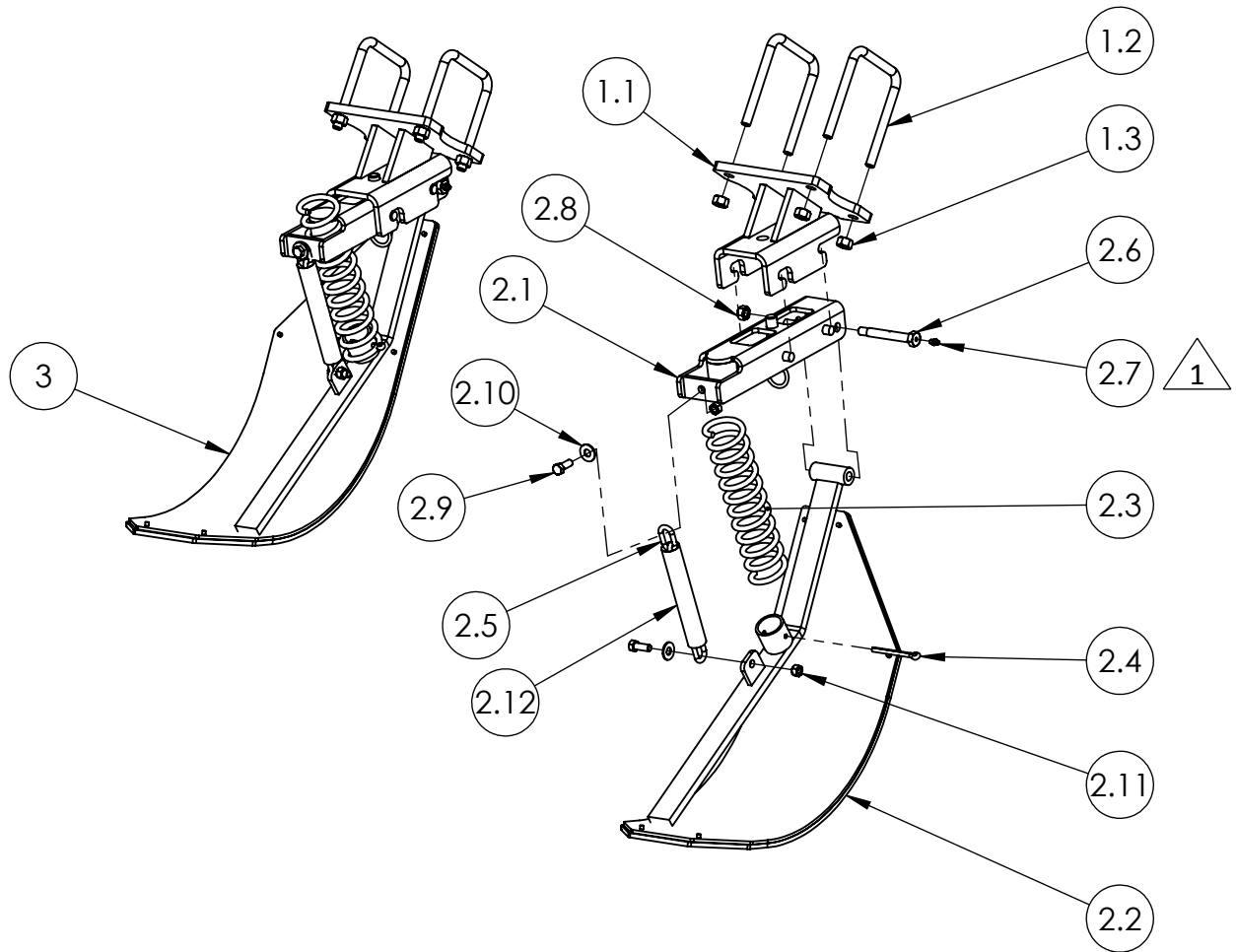

**NOTES:**

**1** Install Self-Tapping Grease Fitting into end of Pivot Bolt  
 Torque grease fitting to 65-70 inch pounds. **DO NOT OVERTIGHTEN!**

| ITEM # | PART # | DESCRIPTION               | QTY | ITEM # | PART # | DESCRIPTION                      | QTY |
|--------|--------|---------------------------|-----|--------|--------|----------------------------------|-----|
| 1      | 43006  | QD2 HEADER BRACKET ASSY   | 2   | 2.5    | 00931  | CHAIN                            | 1   |
| 1.1    | 43007  | QD2 HEADER BRACKET        | 1   | 2.6    | 01001  | BOLT, CUSTOM (GREASEABLE)        | 1   |
| 1.2    | 00965  | U-BOLT 1/2-13             | 2   | 2.7    | 01009  | GREASE FITTING, 1/4"-28 STRAIGHT | 1   |
| 1.3    | 00216  | NUT, 1/2"-13 TOP LOCK     | 4   | 2.8    | 00213  | NUT, 7/16"-14 HEX TOP LOCK       | 1   |
| 2      | 43014  | OFFSET LEFT SS ASSY 9"    | 1   | 2.9    | 00104  | BOLT, 3/8"-16 X 1" HEX           | 2   |
| 2.1    | 43004  | SHOE BRACKET ASSY         | 1   | 2.10   | 00249  | WASHER, 3/8" FLAT                | 2   |
| 2.2    | 41856  | OFFSET LEFT STALK STOMPER | 1   | 2.11   | 00209  | NUT, 3/8"-16 HEX                 | 2   |
| 2.3    | 01040  | SPRING                    | 1   | 2.12   | 01046  | CHAIN SLEEVE                     | 1   |
| 2.4    | 00691  | PIN, 1/4" X 3" COTTER     | 1   | 3      | 43013  | OFFSET RIGHT SS ASSY 9"          | 1   |



**120 Eastgate Drive SE**  
**PO Box 7**  
**Hutchinson, MN 55350**

**1-800-788-6483**  
**1-320-587-2322**  
**1-320-587-6112 (Fax)**

**WWW.MAYWES.COM**

## CASE IH 2600 SERIES - NEW HOLLAND 99C SERIES

ROWS 2 & 5 ON A 6 ROW HEAD

STALK STOMPER INSTALLATION

### Safety Procedure:

- Park combine on level ground and lock the brakes.
- Raise the head and lock in the upright position.

### Installation Procedure:

- Remove the factory metal shield above the 4X4 frame beam on rows that stalk stompers are being installed.
- Place U-Bolts over the top of the 4X4 frame beam.
- Place the Header Bracket (43007) below the 4X4 frame beam on center with the row unit positioning the "hook slots" toward the rear of the head. Align the U-Bolts with Header Bracket and secure in place with the 1/2" top lock nuts, clamping the frame beam.
- Lift the Stalk Stomper Assy (43013/43014) into mating features in the Header Bracket (43007)  
Pull Stalk Stomper Assy back until lock pin snaps into place.
- Replace the factory metal shield.

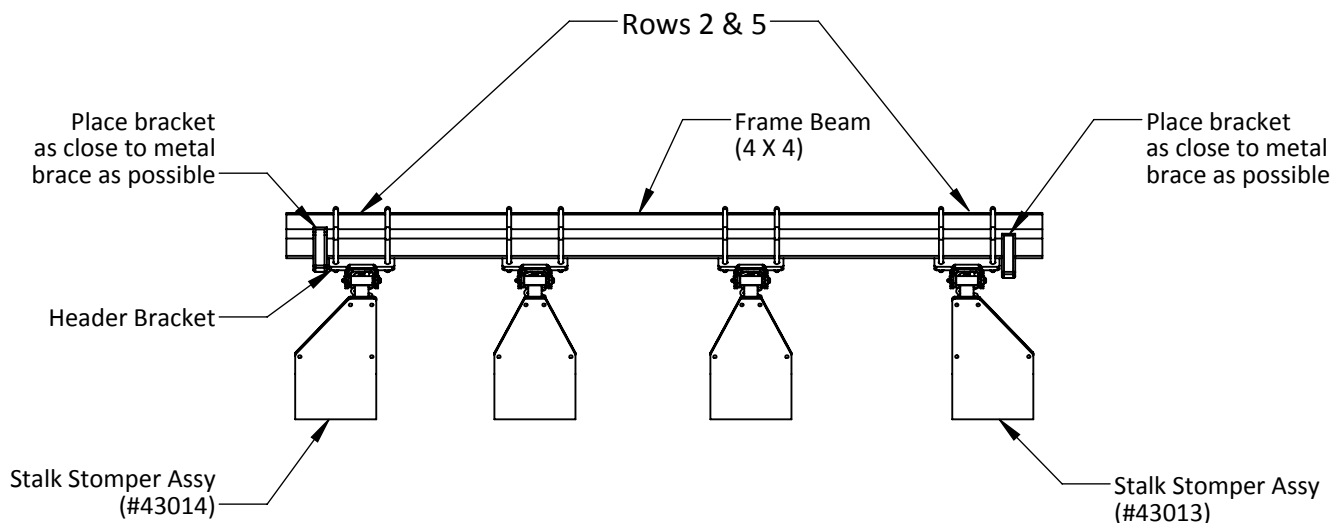

As looking from the front of the Corn Head



120 Eastgate Drive SE  
PO Box 7  
Hutchinson, MN 55350

1-800-788-6483  
1-320-587-2322  
1-320-587-6112 (Fax)

[WWW.MAYWES.COM](http://WWW.MAYWES.COM)