

GERINGHOFF PATRIOT / ROTA DISC / NORTHSTAR G4 TOOLBAR MOUNT STALK STOMPER

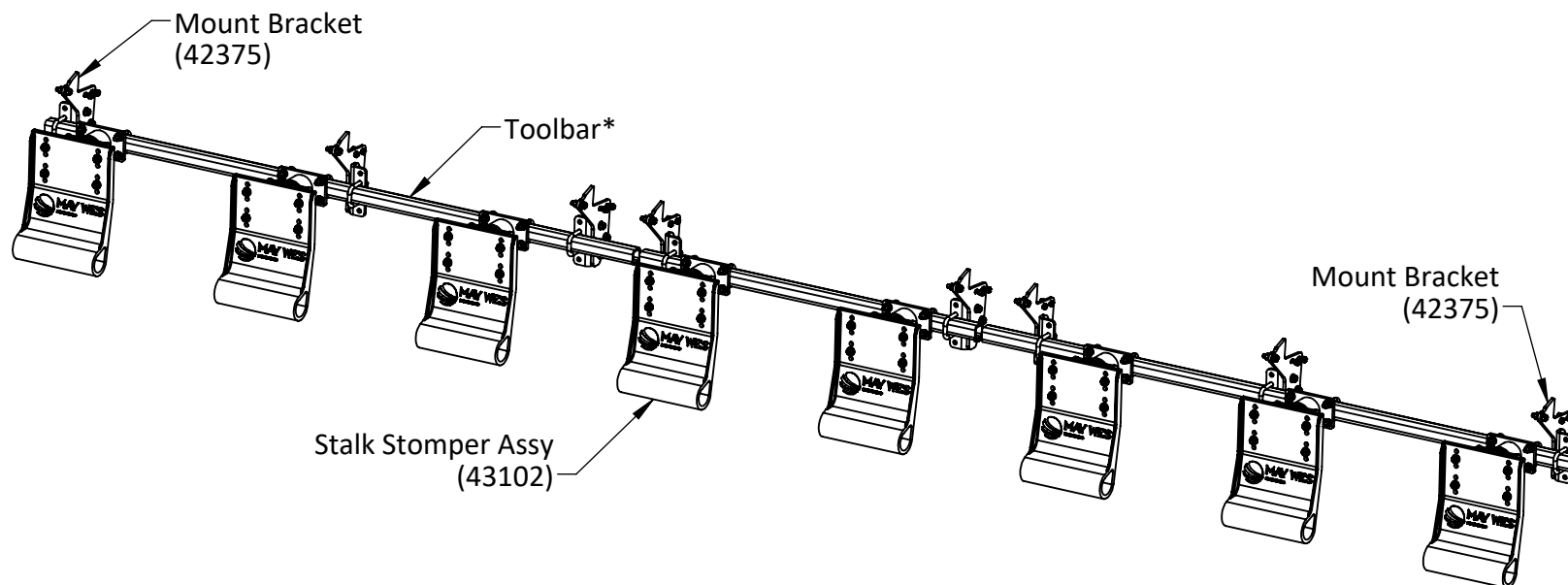

Notes:

- Illustration shown is for reference purposes only. Quantities and components will vary.
Please refer to individual component parts listings for specific information.

* Toolbar is not included in all kits. If a kit without Toolbar was ordered, the customer is responsible for providing required Toolbar.



MAY WES
Original Poly People
A DIVISION OF PRIDE SOLUTIONS

120 Eastgate Drive SE
Hutchinson, MN 55350

1-800-788-6483
1-320-587-2322
1-320-587-6112 (Fax)

WWW.MAYWES.COM

GERINGHOFF PATRIOT / ROTA DISC / NORTHSTAR G4 TOOLBAR MOUNT STALK STOMPER ASSEMBLY/INSTALLATION INSTRUCTIONS

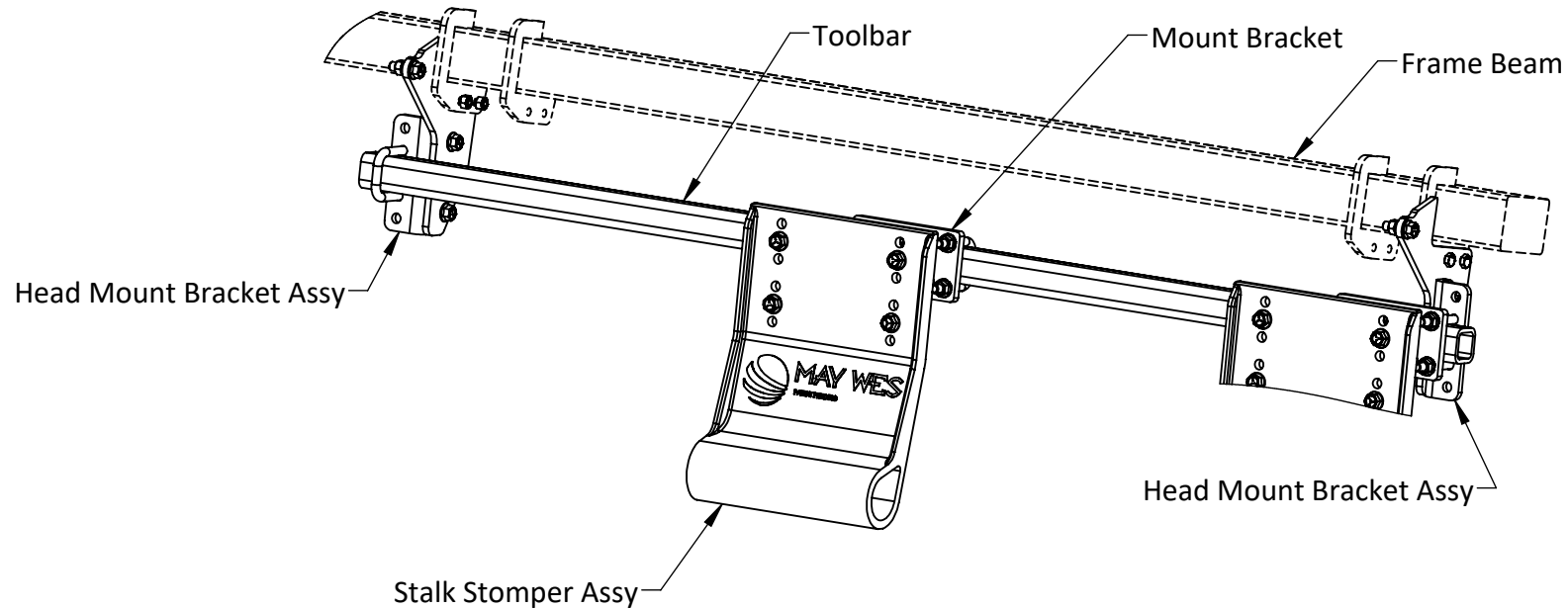

Assembly/Installation Procedure:

- Fasten Head Mount Bracket to mating holes in head frame using supplied Bolts and Lock Nuts
- Fasten Toolbar to Head Mount Brackets using supplied U-Bolts, Lock Washers and Nuts
Note: Second set of holes in Head Mount Bracket will adjust toolbar height by one inch (1")
- Fasten Mount Brackets to Toolbar using supplied U-Bolts, Lock Washers and Nuts on center of the rows to be stomped.
- Lift Stalk Stomper Assy into mating features in the Mount Bracket.
Pull Stalk Stomper Assy back until lock pin assembly snaps into place.



MAY WES
Original Poly People
A DIVISION OF PRIDE SOLUTIONS

120 Eastgate Drive SE
Hutchinson, MN 55350

1-800-788-6483
1-320-587-2322
1-320-587-6112 (Fax)

WWW.MAYWES.COM

**GERINGHOFF
PATRIOT / ROTA DISC / NORTHSTAR
G4 TOOLBAR MOUNT STALK STOMPER
OPTIONAL SETUPS**

Overlapping Brackets

If necessary, Mount Brackets and Head Mount Brackets can be overlapped to allow the Stalk Stomper Assy to be positioned on center of the row. Replace U-Bolt with 1/2"-13 x 4" Hex Bolts as shown.

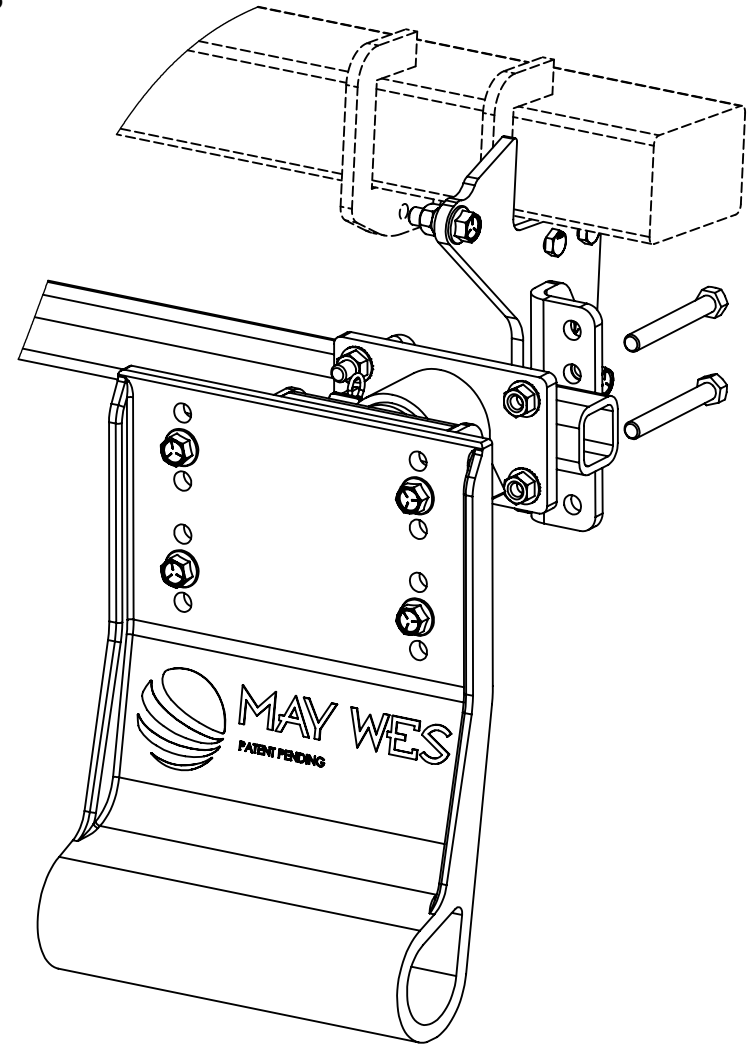

MAY WES
Original Poly People
A DIVISION OF PRIDE SOLUTIONS

120 Eastgate Drive SE
Hutchinson, MN 55350

1-800-788-6483
1-320-587-2322
1-320-587-6112 (Fax)

WWW.MAYWES.COM

GERINGHOFF TOOLBAR MOUNT STALK STOMPER ASSEMBLY INSTRUCTIONS / PARTS LISTING

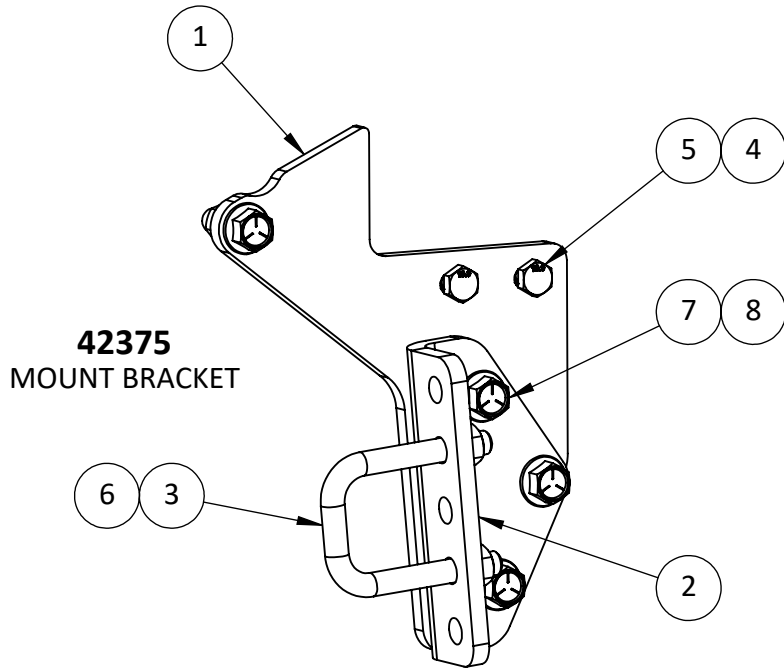

ITEM #	PART #	DESCRIPTION	QTY
1	42371	PLATE MOUNTING GERINGHOFF	1
2	42372	BRKT FORMED GERINGHOFF	1
3	00986	U-BOLT 1/2"-13 X 2"	1
4	01052	Nut M10-1.5 Toplock	2
5	01053	Bolt M10-1.5 X 35mm Hex	2
6	00730	NUT, 1/2"-13 HEX FLANGE	2
7	00729	BOLT, 1/2"-13 X 1-1/2" HEX FLANGE	4
8	00216	NUT, 1/2" NC TOP LOCK	4

41827 (OPTIONAL) TOOLBAR SPLICE

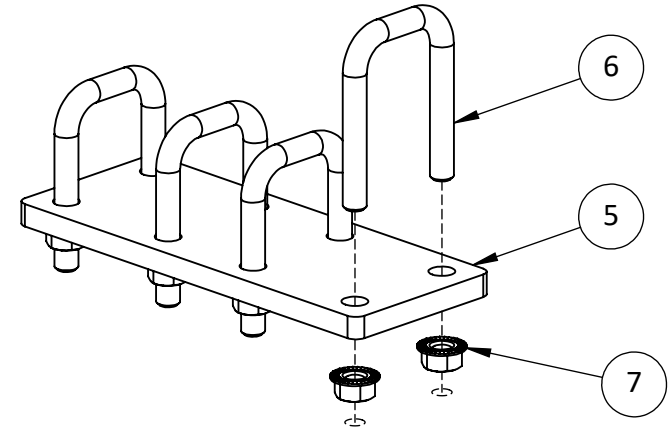

ITEM #	PART #	DESCRIPTION	QTY
5	22341	SPLICE PLATE	1
6	00986	U-BOLT 1/2"-13 X 2"	4
7	00730	NUT, 1/2"-13 HEX FLANGE	8

Items 9 and 10 listed below (but not shown) are not included in all kits, please order individually if needed.

ITEM #	PART #	DESCRIPTION	QTY
9	41672	72" TOOLBAR (2" X 2")	VARIABLES
10	41673	102" TOOLBAR (2" X 2")	VARIABLES
28.11	00729	BOLT, 1/2"-13 X 1-1/2" HEX FLANGE	4
31.8	00729	BOLT, 1/2"-13 X 1-1/2" HEX FLANGE	4
31.9	00216	NUT, 1/2" NC TOP LOCK	4
32.8	00729	BOLT, 1/2"-13 X 1-1/2" HEX FLANGE	4
32.9	00216	NUT, 1/2" NC TOP LOCK	4



120 Eastgate Drive SE
Hutchinson, MN 55350

1-800-788-6483
1-320-587-2322
1-320-587-6112 (Fax)

WWW.MAYWES.COM

43102
G4 TOOLBAR MOUNT
STALK STOMPER ASSEMBLY

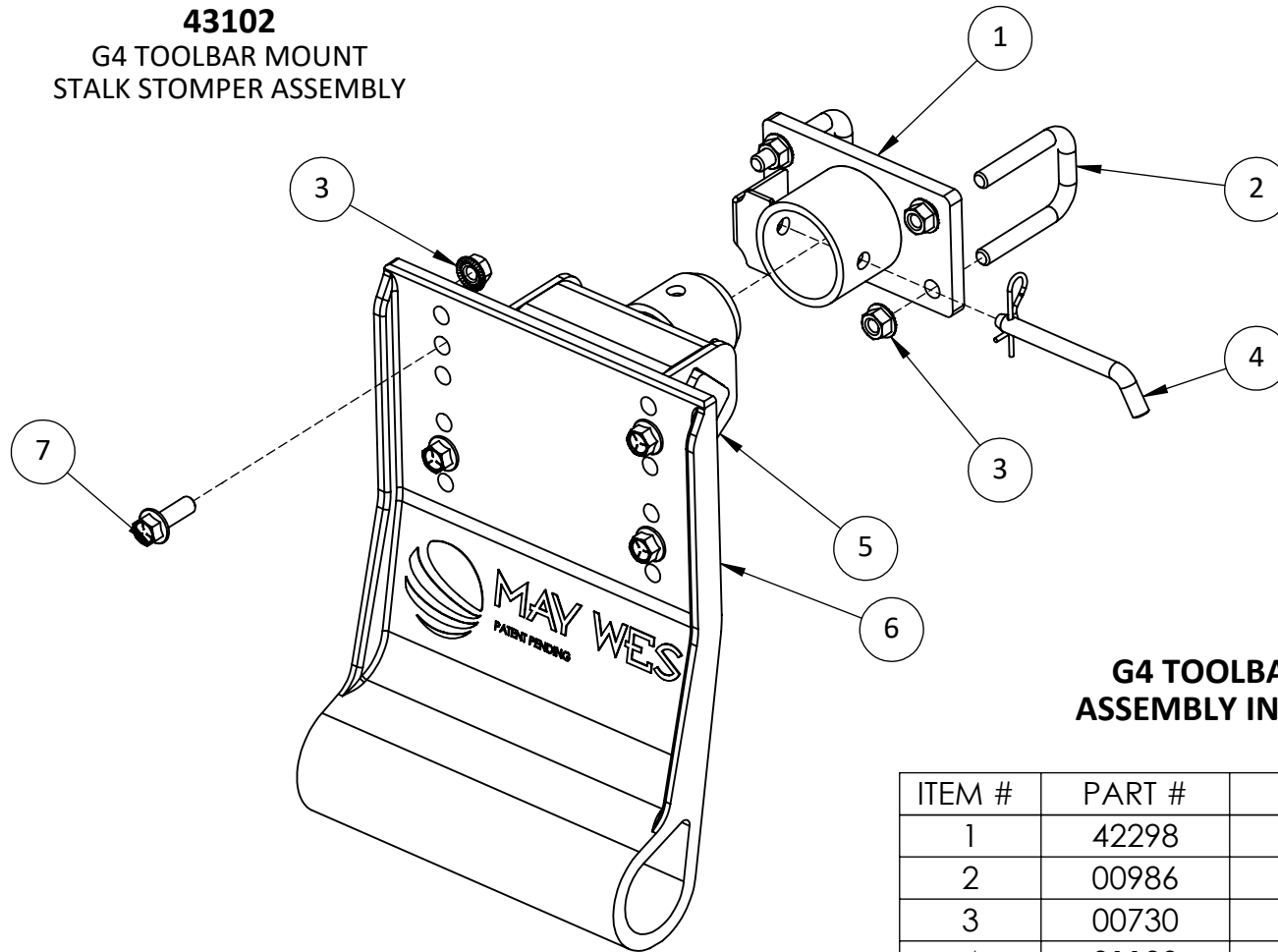

G4 TOOLBAR MOUNT STALK STOMPER
ASSEMBLY INSTRUCTIONS / PARTS LISTING

ITEM #	PART #	DESCRIPTION	QTY
1	42298	WLDMT; TOOLBAR MNT BRKT	1
2	00986	U-BOLT 1/2"-13 X 2"	2
3	00730	NUT, 1/2"-13 HEX FLANGE	8
4	01130	PIN, 1/2" X 4" BENT HITCH	1
5	42295	STALK STOMPER TORSION ASSY	1
6	24100	SHOE, G4 MOLDED	1
7	00729	BOLT, 1/2"-13 X 1-1/2" HEX FLANGE	4



120 Eastgate Drive SE
 Hutchinson, MN 55350

1-800-788-6483
 1-320-587-2322
 1-320-587-6112 (Fax)

WWW.MAYWES.COM