

Case IH 2600 / 4200 / 4400 SERIES - New Holland 99C/980 G4 TOOLBAR MOUNT STALK STOMPER

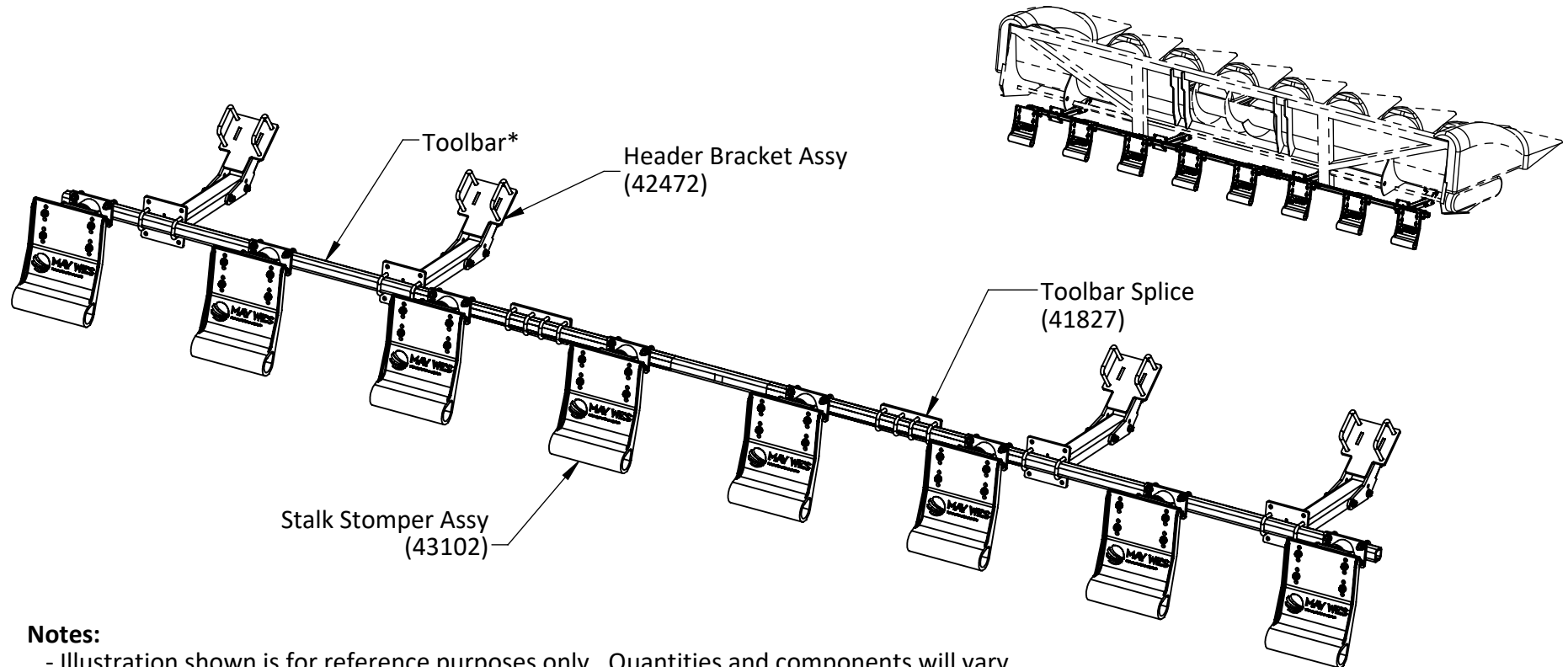

CAUTION

PLEASE REFER TO YOUR EQUIPMENT MANUFACTURER'S OPERATORS MANUAL FOR PERTINENT SAFETY PRECAUTIONS



Notes:

- Illustration shown is for reference purposes only. Quantities and components will vary. Please refer to individual component parts listings for specific information.

* Toolbar is not included in all kits. If a kit without Toolbar was ordered, the customer is responsible for providing required Toolbar.



120 Eastgate Drive SE
Hutchinson, MN 55350

1-800-788-6483
1-320-587-2322
1-320-587-6112 (Fax)

WWW.MAYWES.COM

Case IH 2600 / 4200 / 4400 SERIES - New Holland 99C/980
G4 TOOLBAR MOUNT STALK STOMPER

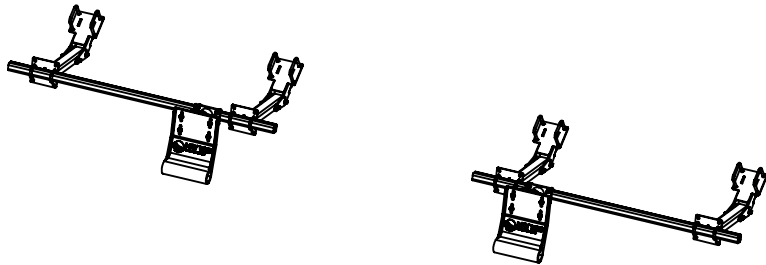

2 Row Layout

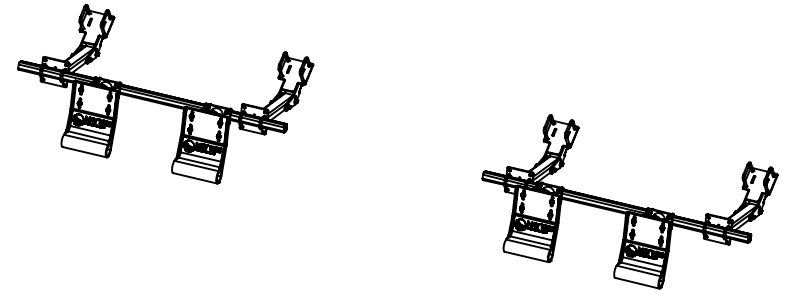

4 Row Layout

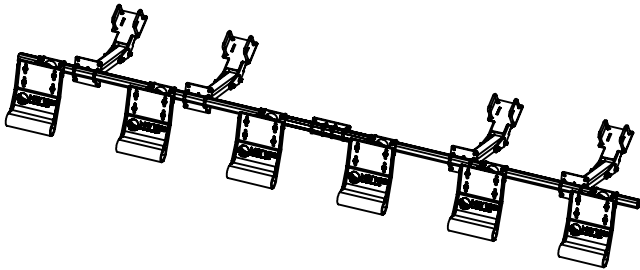

6 Row Layout

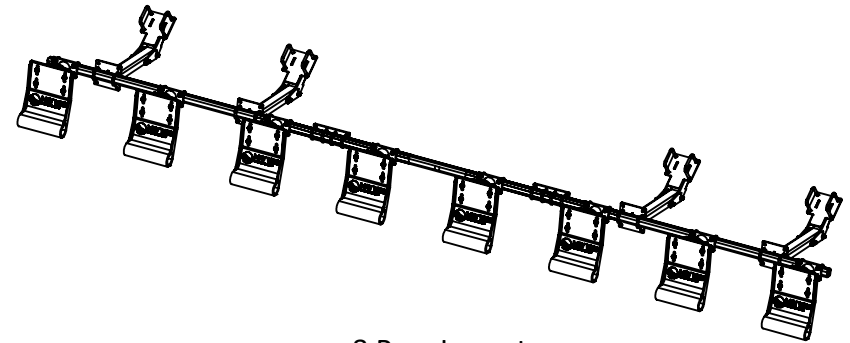

8 Row Layout



120 Eastgate Drive SE
Hutchinson, MN 55350

1-800-788-6483
1-320-587-2322
1-320-587-6112 (Fax)

WWW.MAYWES.COM

Case IH 2600 / 4200 / 4400 SERIES - New Holland 99C/980 G4 TOOLBAR MOUNT STALK STOMPER

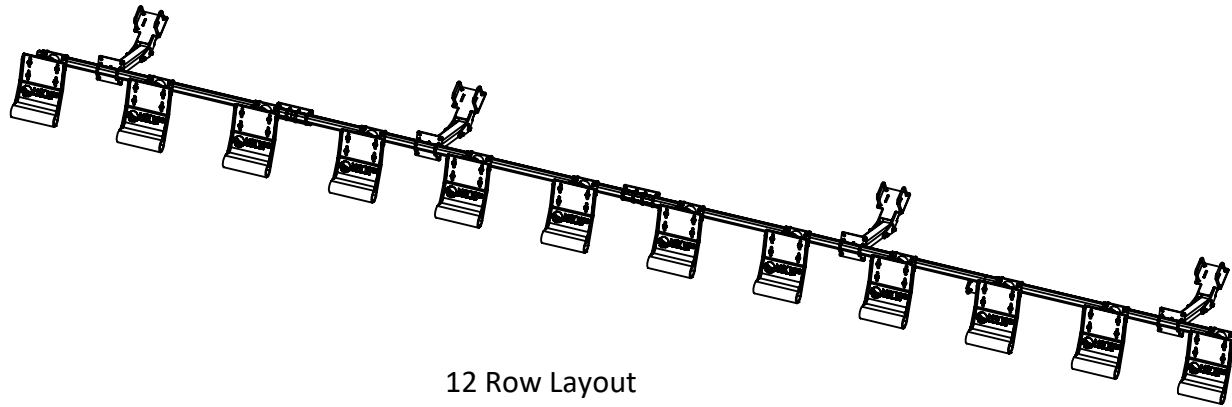

12 Row Layout

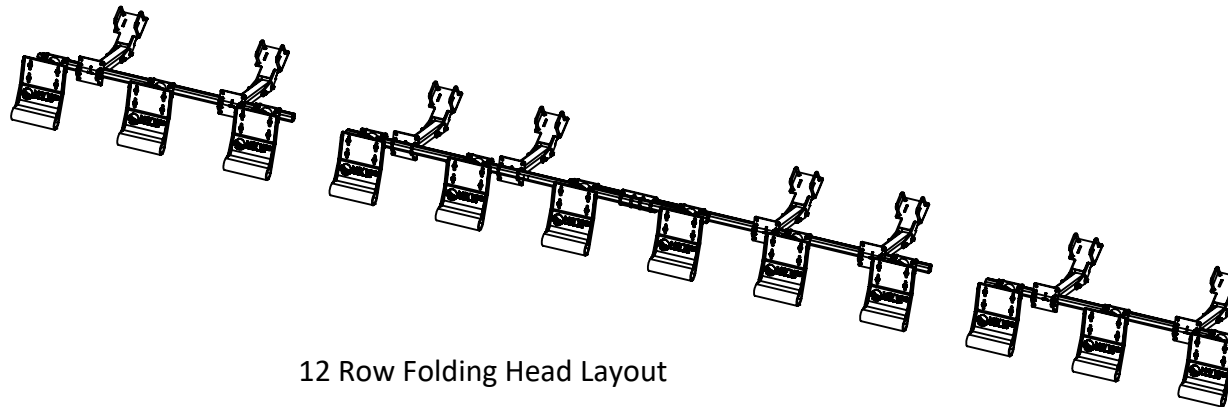

12 Row Folding Head Layout

Case IH 2600 / 4200 / 4400 SERIES - New Holland 99C/980 G4 TOOLBAR MOUNT STALK STOMPER

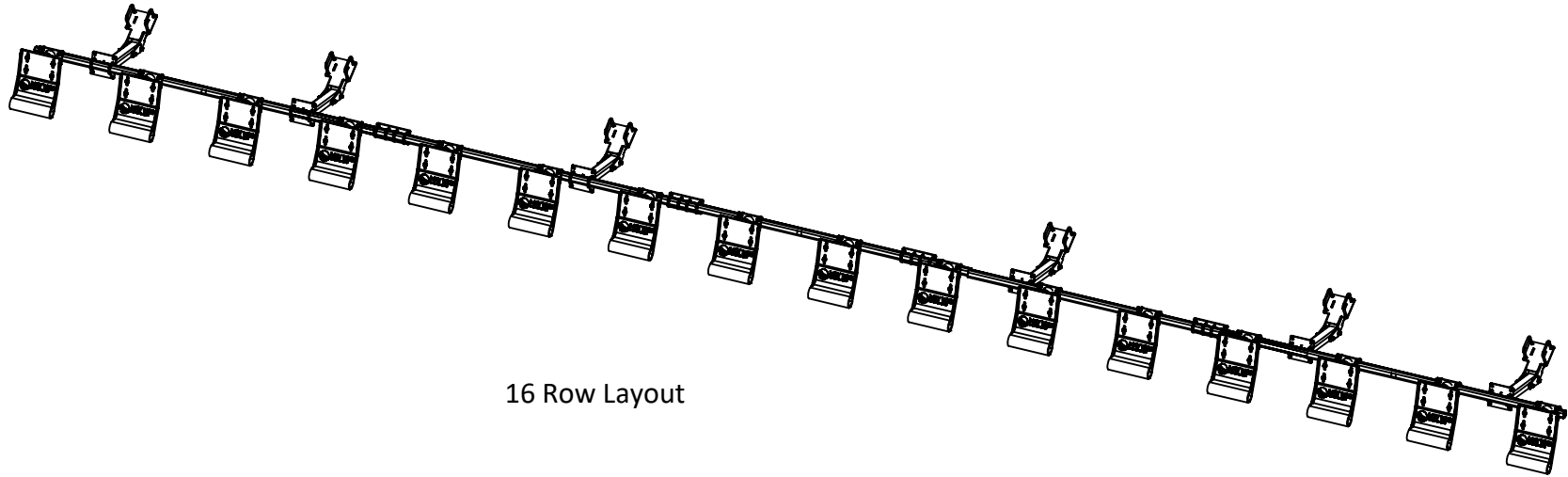

16 Row Layout

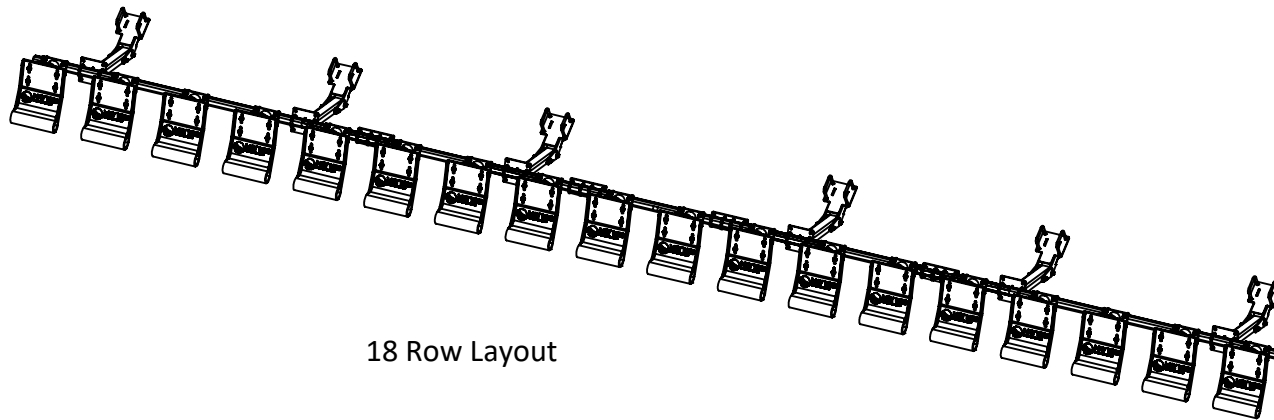

18 Row Layout



120 Eastgate Drive SE
Hutchinson, MN 55350

1-800-788-6483
1-320-587-2322
1-320-587-6112 (Fax)

WWW.MAYWES.COM

Case IH 2600 / 4200 / 4400 SERIES - New Holland 99C/980 G4 TOOLBAR MOUNT STALK STOMPER

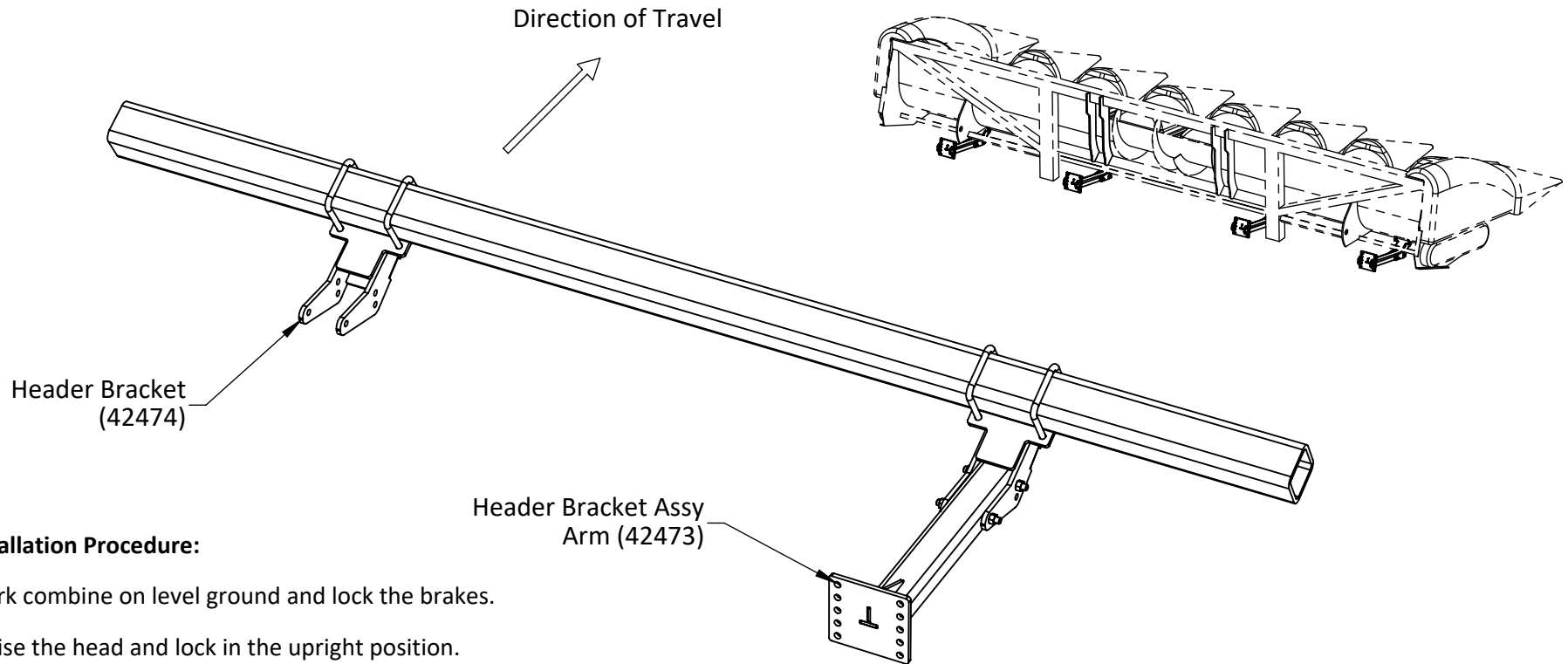

Installation Procedure:

- Park combine on level ground and lock the brakes.
- Raise the head and lock in the upright position.
- Mount the Header Brackets (42474) to the 4" x 4" frame beam on the bottom of the corn head. Place the U-Bolts over the top of the 4 x 4 frame beam.
- Position the Header Brackets, between the row units.
 - It is suggested that a Header Bracket be placed inside the outer most row units on each side of the head
 - It is suggested that a Header Bracket be placed between row units, just outside of the feeder house of the combine.
 - Keep as much distance between brackets as possible.

Note: Locations may vary depending on the model.

- Attach the Header Bracket Arm (42473) to the Header Bracket, using the bolts provided in the kit.



120 Eastgate Drive SE
Hutchinson, MN 55350

1-800-788-6483
1-320-587-2322
1-320-587-6112 (Fax)

WWW.MAYWES.COM

Case IH 2600 / 4200 / 4400 SERIES - New Holland 99C/980 G4 TOOLBAR MOUNT STALK STOMPER

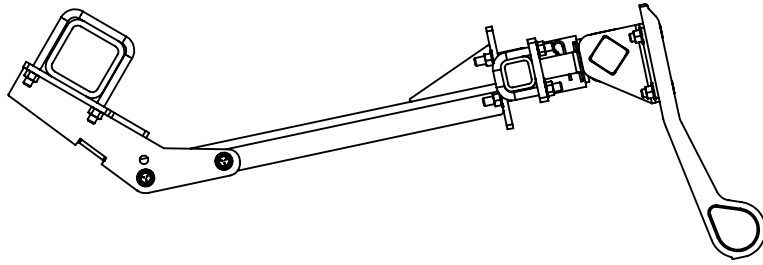

Position 1

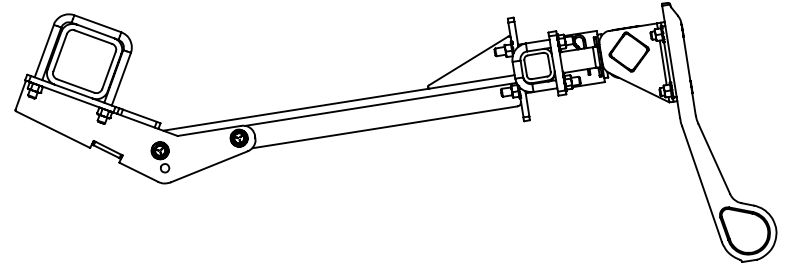

Position 2

Adjustable Settings

- The Bracket is designed to fit multiple versions of the Case IH 2600, 4200 and 4400 Corn Heads.
- **Position 1** is the most common setup.
 - It is recommended that you start with this setup.
- **Position 2** is a setup used on newer heads with all drivelines mounted under the head.
- Mount toolbar (2" x 2" square tube) to the mounting brackets using the 2" U-Bolts and lock nuts provided.
Note: Toolbars may need to be trimmed to fit.
- Connect tool bars with splice plates, where needed.
NOTE: Make sure splice brackets do not interfere with positions of the Stalk Stomper Units



120 Eastgate Drive SE
Hutchinson, MN 55350

1-800-788-6483
1-320-587-2322
1-320-587-6112 (Fax)

WWW.MAYWES.COM

Case IH 2600 / 4200 / 4400 SERIES - New Holland 99C/980 G4 TOOLBAR MOUNT STALK STOMPER

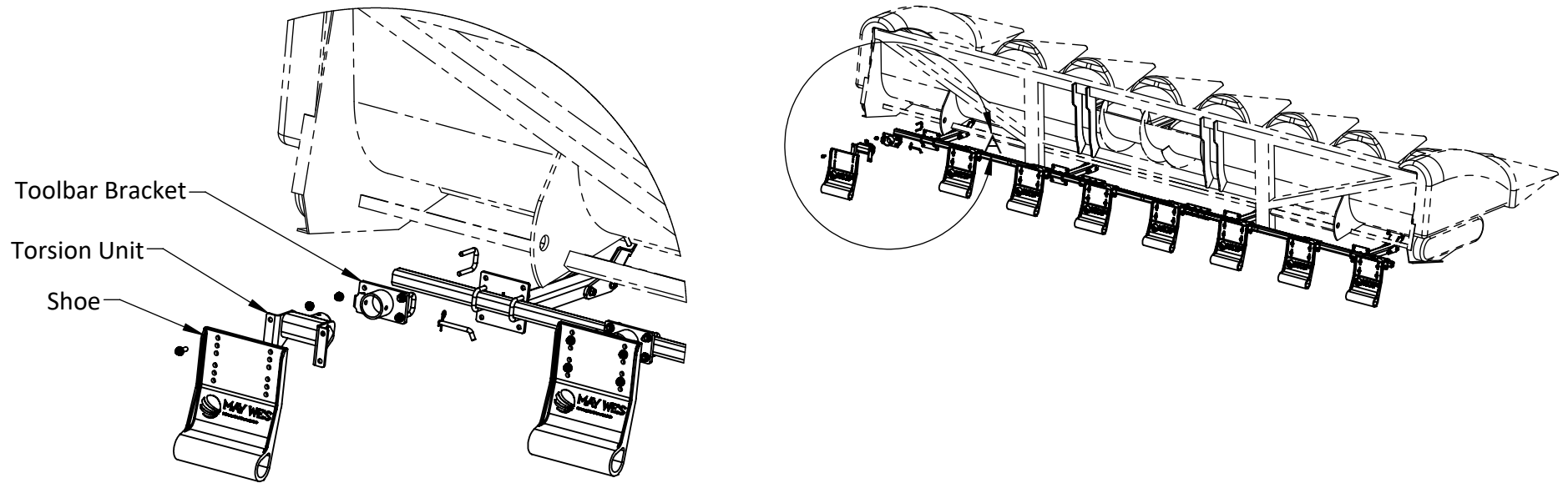

Installation Procedure:

- On flat ground, lower the head to approximate working height.
- Attach Toolbar Brackets (42298) using U-Bolts and nuts, behind the center of each row to be stomped.
- Lift Stalk Shoe Assembly into mating features on the mounting bracket and attach with pin and clip.
- Height can be adjusted by repositioning the shoe to the torsion unit. Each set of holes will adjust the height by 1"

NOTE:

Refer to G4 Stalk Stomper Instruction (Document 10274) for Setup, Operation, Maintenance, Transport and Storage Instructions



120 Eastgate Drive SE
Hutchinson, MN 55350

1-800-788-6483
1-320-587-2322
1-320-587-6112 (Fax)

WWW.MAYWES.COM

**Case IH 2600 / 4200 / 4400 SERIES - New Holland 99C/980
G4 TOOLBAR MOUNT STALK STOMPER**

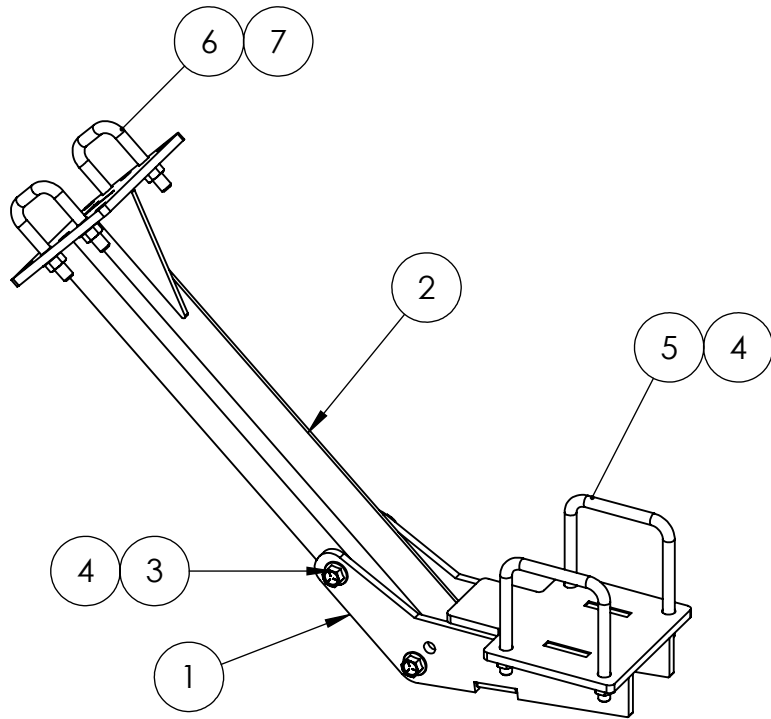

42472 - Header Bracket Assembly

7	00730	NUT, 1/2"-13 HEX FLANGE	4
6	00986	U-BOLT 1/2"-13 X 2"	2
5	00965	U-BOLT 1/2"-13 x 4"	2
4	00216	NUT, 1/2" NC TOP LOCK	8
3	00729	BOLT, 1/2"-13 X 1-1/2" FLANGE	4
2	42473	BRACKET, CIH G4 ADJ TB	1
1	42474	BRACKET, CIH G4 RETROFIT	1
ITEM #	PART #	DESCRIPTION	QTY.

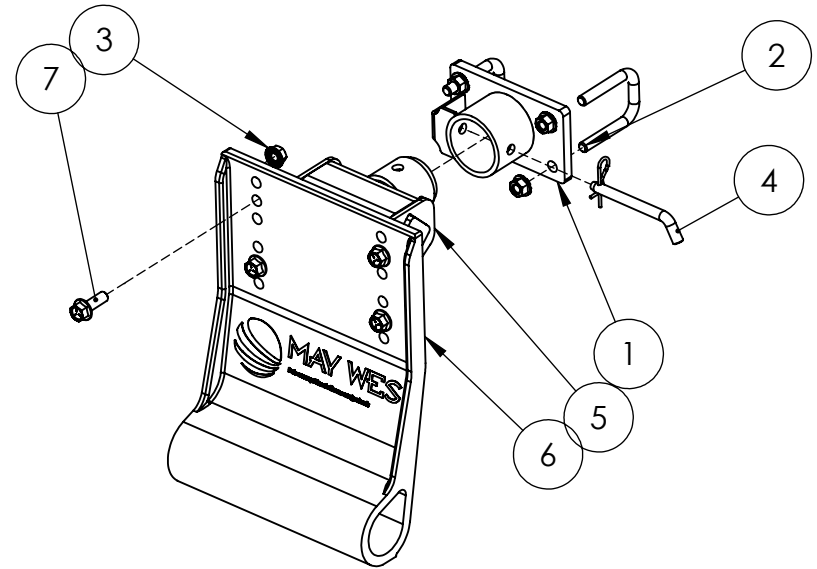

43102 - Stalk Stomper Shoe Assembly

7	00729	BOLT, 1/2"-13 X 1-1/2" HEX FLANGE	4
6	24100	SHOE, G4 MOLDED	1
5	42295	STALK STOMPER TORSION ASSY	1
4	01130	PIN, 1/2" X 4" BENT HITCH	1
3	00730	NUT, 1/2"-13 HEX FLANGE	8
2	00986	U-BOLT 1/2"-13 X 2"	2
1	42298	WLDMT; TOOLBAR MNT BRKT	1
ITEM #	PART #	DESCRIPTION	QTY.



120 Eastgate Drive SE
Hutchinson, MN 55350

1-800-788-6483
1-320-587-2322
1-320-587-6112 (Fax)

WWW.MAYWES.COM