

**41689**  
**LIFT ARM ASSY (LEFT)**  
**TRACTOR STALK STOMPER**  
**PARTS LISTING**

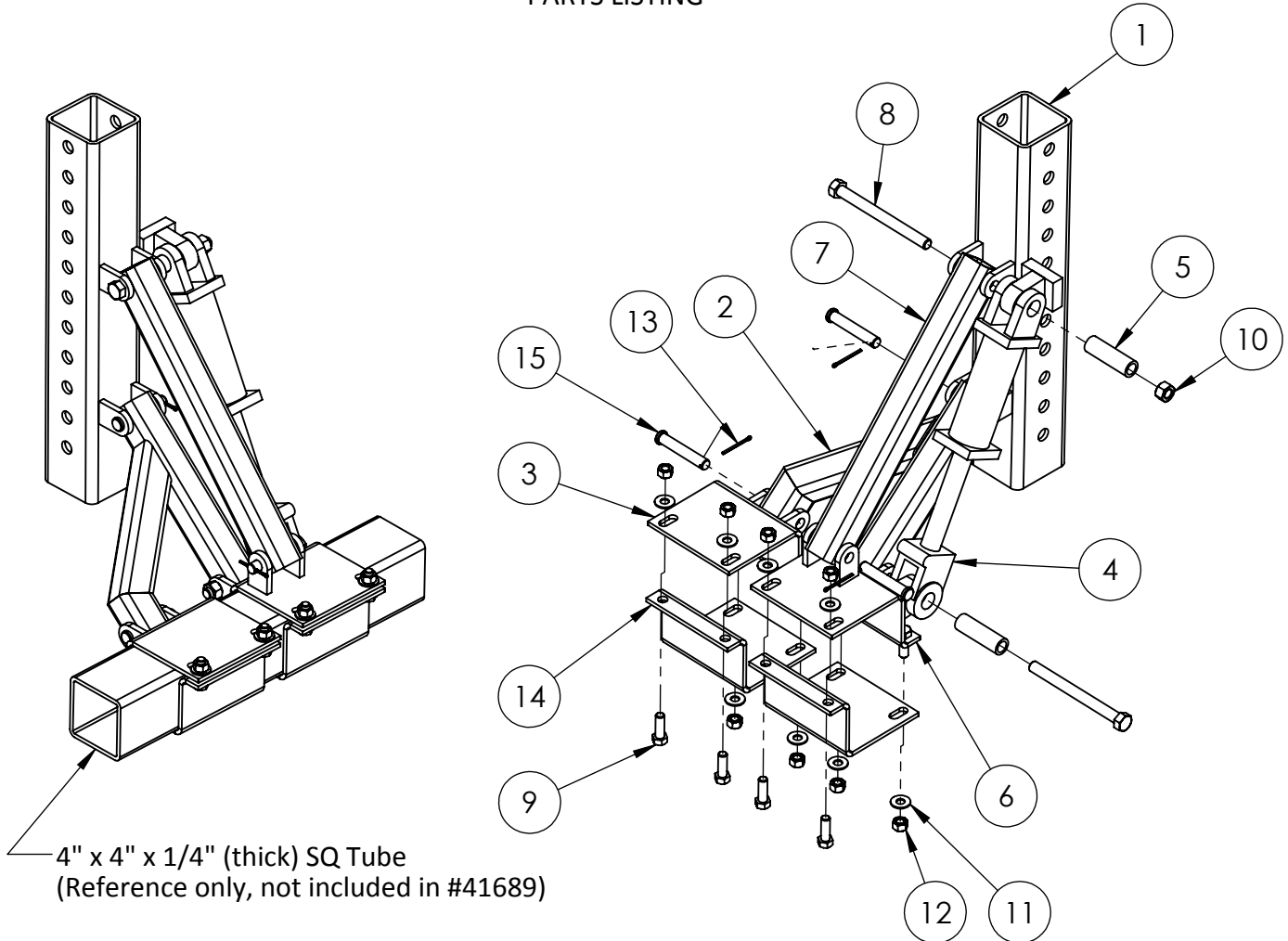

4" x 4" x 1/4" (thick) SQ Tube  
 (Reference only, not included in #41689)

**NOTES:**

- To order a complete stalk stomper, use part number #41689
- To order individual sevice items, select item number from the illustration above and cross reference the parts list below for the part number and description.

ITEM#	PART#	DESCRIPTION	QTY	ITEM#	PART#	DESCRIPTION	QTY
1	41691	VERTICAL MOUNT	1	9	00135	BOLT, 1/2"-13 X 1-1/2" HEX	8
2	41692	LOWER CONNECTOR ARM	1	10	00197	NUT, 5/8"-11 TOP LOCK	2
3	41694	SMALL BRACKET	1	11	00253	WASHER, 1/2" FLAT SAE	8
4	00961	HYDRAULIC CYLINDER	1	12	00216	NUT, 1/2"-13 TOP LOCK	8
5	22255	SLEEVE BUSHING	2	13	00964	COTTER PIN, 1/8" X 2" LG	3
6	41695	LARGE BRACKET	1	14	22264	CLAMP	2
7	41696	UPPER ARM	1	15	00963	CLEVIS PIN, 5/8" X 3-1/2" LG	3
8	00962	BOLT, 5/8"-11 X 7" HEX	2				



**120 Eastgate Drive SE**  
**PO Box 7**  
**Hutchinson, MN 55350**

**1-800-788-6483**  
**1-320-587-2322**  
**1-320-587-6112 (Fax)**

**WWW.MAYWES.COM**

**41689**  
**LIFT ARM ASSY (LEFT)**  
**TRACTOR STALK STOMPER**  
**INSTALLATION**

**Safety Procedure:**

-Park Tractor on level ground and engage the parking brake

**Installation Procedure:**

-Attach Vertical Mount (#41691) to mounting bracket\* on tractor with two (2) 3/4" Grade 5 bolts\*\*, two (2) flat washers\*\*, and two (2) 3/4" locking nuts\*\*. Minimum recommended bolt spacing on vertical mount is 6" (two holes between bolts).

**Note:**

-Lift Arm Assembly must be mounted to allow for 2" of ground clearance to the bottom of the Stalk Stomper shoe when the entire assembly is in the operating (down) position (see figure 1). Also to allow for a minimum of 12" of clearance between the tractor tire/track and the back edge of the Stalk Stomper shoe when the ntire assembly is in transport (up) position (see figure 2).

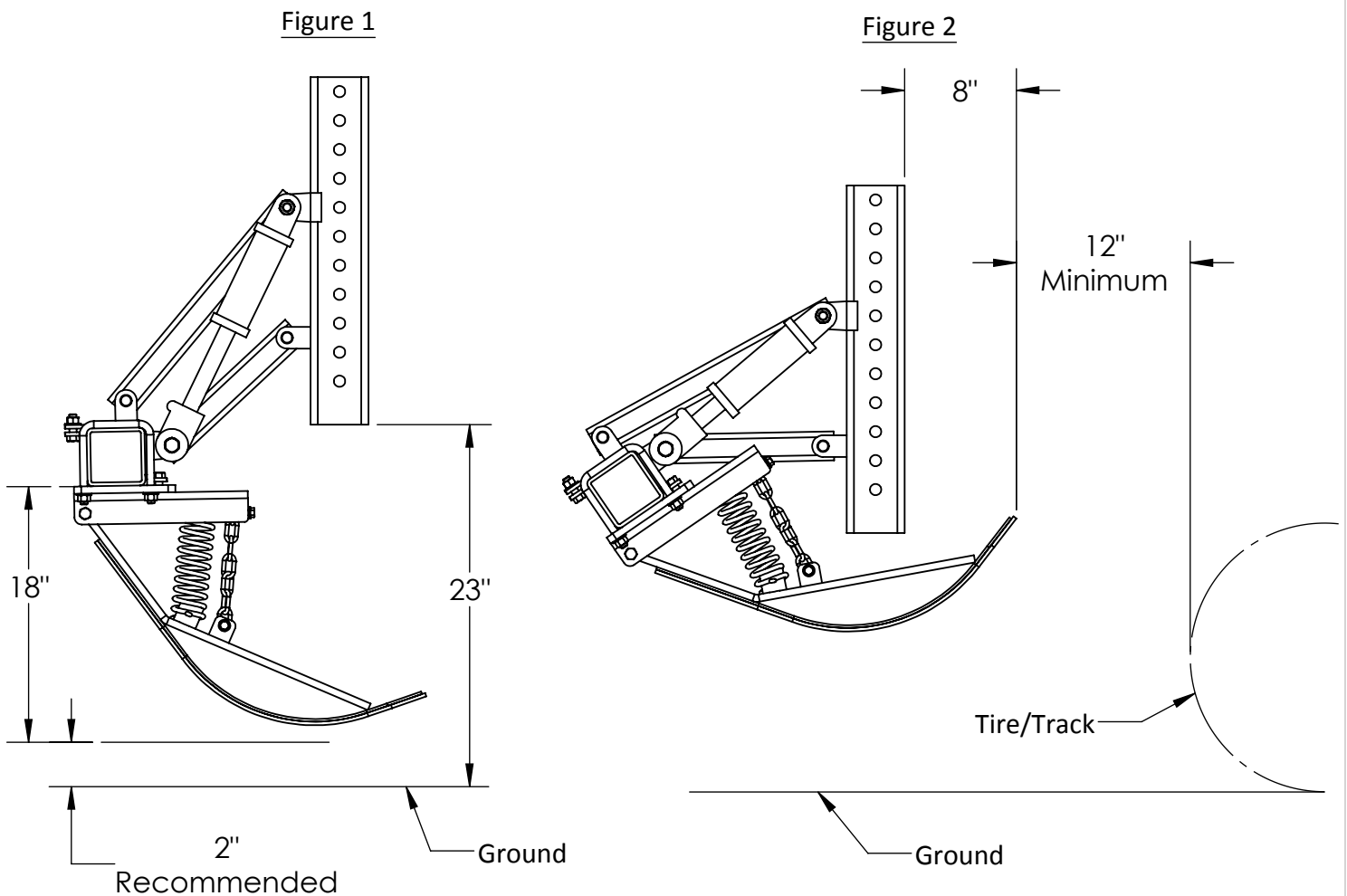

\* Tractor mounting bracket sold separately or supplied by the customer.  
\*\* 3/4" Bolts, 3/4" Flat Washers & 3/4" Locking Nuts are recommended hardware and are not supplied with Lift Arm Assembly



120 Eastgate Drive SE  
PO Box 7  
Hutchinson, MN 55350

1-800-788-6483  
1-320-587-2322  
1-320-587-6112 (Fax)

[WWW.MAYWES.COM](http://WWW.MAYWES.COM)